

< DIIPM >

PSS25NC1FT

TRANSFER MOLDING TYPE
INSULATED TYPE

OUTLINE

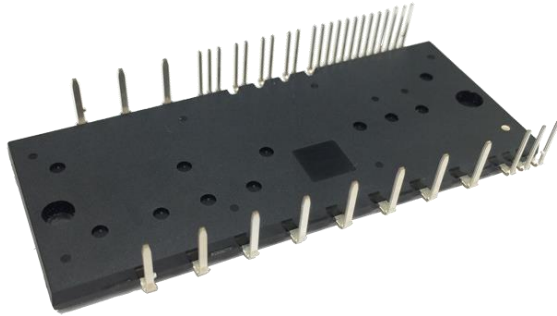

MAIN FUNCTION

CI(Converter + Inverter) type IPM

- 3-phase Inverter
- 3-phase Converter

RATING

- Inverter part : 25A/1200V (CSTBT)

APPLICATION

- AC400V three phase motor inverter drive

* With brake circuit type 'PSS25MC1FT' is also available.

INTEGRATED DRIVE, PROTECTION AND SYSTEM CONTROL FUNCTIONS

- For P-side : Drive circuit, High voltage high-speed level shifting,
Control supply under-voltage protection (UV) without fault signal output
Built-in discrete bootstrap diode chips with current limiting resistor
- For N-side : Drive circuit, Control supply under-voltage protection (UV),
Short circuit protection (SC) by detecting voltage of external shunt resistor
- Fault signaling : Corresponding to SC fault (N-side IGBT) and UV fault (N-side supply)
- Temperature monitoring : Outputting LVIC temperature by analog signal (No self over temperature protection)
- Input interface : 5V high active logic
- UL Recognized : UL1557 File E323585

INTERNAL CIRCUIT

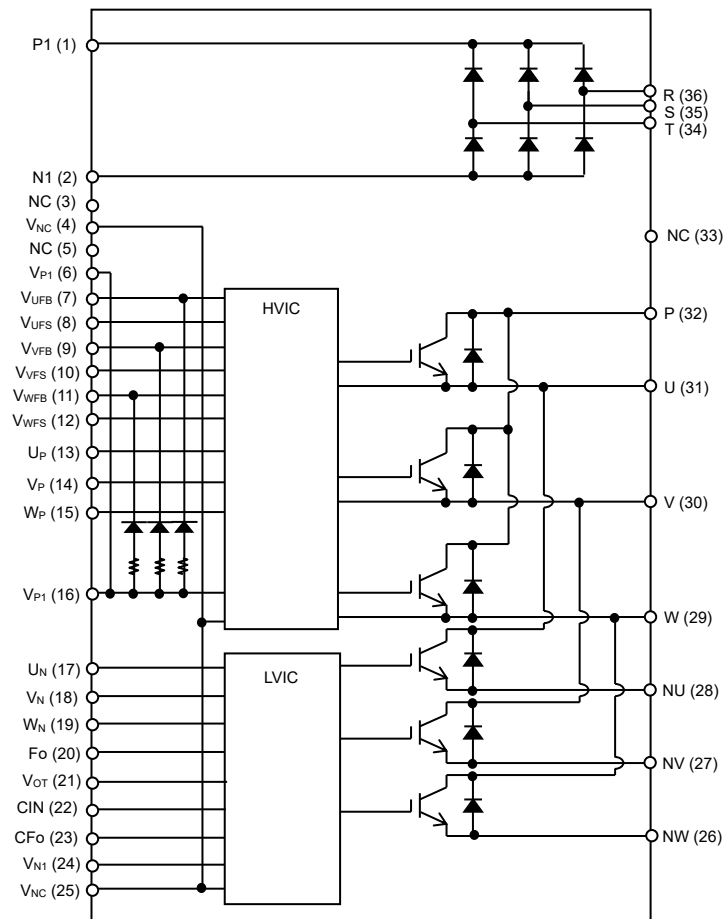

PSS25NC1FT

TRANSFER MOLDING TYPE
INSULATED TYPE

MAXIMUM RATINGS (T_j = 25°C, unless otherwise noted)

INVERTER PART

Symbol	Parameter	Condition	Ratings	Unit
V _{CC}	Supply voltage	Applied between P-NU,NV,NW	900	V
V _{CC(surge)}	Supply voltage (surge)	Applied between P-NU,NV,NW	1000	V
V _{CES}	Collector-emitter voltage		1200	V
±I _C	Each IGBT collector current	T _C = 25°C (Note 1)	25	A
±I _{CP}	Each IGBT collector current (peak)	T _C = 25°C, less than 1ms	50	A
T _j	Junction temperature		-30~+150	°C

Note1: Pulse width and period are limited due to junction temperature.

CONVERTER PART

Symbol	Parameter	Condition	Ratings	Unit
V _{RRM}	Repetitive peak reverse voltage		1600	V
I _o	DC output current	3-phase full wave rectification	25	A
I _{FSM}	Surge forward current	Peak value of half cycle at 60Hz, Non-repetitive	315	A
I ² t	I ² t capability	Value for 1 cycle of surge current	416	A ² s
T _j	Junction temperature		-30~+150	°C

CONTROL (PROTECTION) PART

Symbol	Parameter	Condition	Ratings	Unit
V _D	Control supply voltage	Applied between V _{P1} -V _{NC} , V _{N1} -V _{NC}	20	V
V _{DB}	Control supply voltage	Applied between V _{UFB} -V _{UFS} , V _{VFB} -V _{VFS} , V _{WFB} -V _{WFS}	20	V
V _{IN}	Input voltage	Applied between U _P , V _P , W _P , U _N , V _N , W _N -V _{NC}	-0.5~-V _D +0.5	V
V _{FO}	Fault output supply voltage	Applied between F _O -V _{NC}	-0.5~-V _D +0.5	V
I _{FO}	Fault output current	Sink current at F _O terminal	5	mA
V _{SC}	Current sensing input voltage	Applied between C _{IN} -V _{NC}	-0.5~-V _D +0.5	V

TOTAL SYSTEM

Symbol	Parameter	Condition	Ratings	Unit
V _{CC(PROT)}	Self protection supply voltage limit (Short circuit protection capability)	V _D = 13.5~16.5V, Inverter Part T _j = 125°C, non-repetitive, less than 2μs	800	V
T _C	Module case operation temperature	(Note 2)	-30~+110	°C
T _{stg}	Storage temperature		-40~+125	°C
V _{iso}	Isolation voltage	60Hz, Sinusoidal, AC 1min, between connected all pins and heat sink plate	2500	V _{rms}

Note2: Measurement point of T_c is described in Fig.1.

Fig. 1 Measurement point of T_c

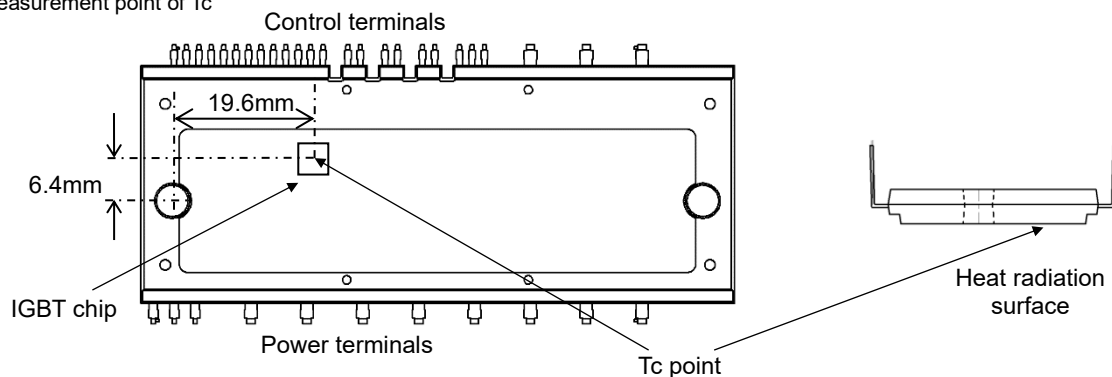

THERMAL RESISTANCE

Symbol	Parameter	Condition	Limits			Unit
			Min.	Typ.	Max.	
R _{th(j-c)Q}	Junction to case thermal resistance (Note 3)	Inverter IGBT part (per 1/6 module)	-	-	1.15	K/W
R _{th(j-c)F}		Inverter FWD part (per 1/6 module)	-	-	1.65	
R _{th(j-c)R}		Converter part (per 1/6 module)	-	-	1.10	

Note 3: Grease with good thermal conductivity and long-term endurance should be applied evenly with about +100μm~+200μm on the contacting surface of DIIPM and heat sink. The contacting thermal resistance between DIIPM case and heat sink R_{th(c-f)} is determined by the thickness and the thermal conductivity of the applied grease. For reference, R_{th(c-f)} is about 0.25K/W (per 1chip, grease thickness: 20μm, thermal conductivity: 1.0W/m·K).

PSS25NC1FT

TRANSFER MOLDING TYPE
INSULATED TYPE

ELECTRICAL CHARACTERISTICS (T_j = 25°C, unless otherwise noted)

INVERTER PART

Symbol	Parameter	Condition	Limits			Unit
			Min.	Typ.	Max.	
V _{CE(sat)}	Collector-emitter saturation voltage	V _D =V _{DB} = 15V, V _{IN} = 5V	-	1.50	2.20	V
		I _C = 25A, T _j = 25°C	-	1.80	2.45	
V _{EC}	FWDi forward voltage	V _{IN} = 0V, -I _C = 25A	-	2.40	3.10	V
t _{on}	Switching times	V _{CC} = 600V, V _D = V _{DB} = 15V I _C = 25A, T _j = 125°C, V _{IN} = 0→5V Inductive Load (upper-lower arm)	1.10	1.90	2.60	μs
t _{C(on)}			-	0.60	0.90	μs
t _{off}			-	2.80	3.80	μs
t _{C(off)}			-	0.50	0.90	μs
t _{tr}			-	0.60	-	μs
I _{CES}	Collector-emitter cut-off current	V _{CE} =V _{CES}	-	-	1	mA
		T _j = 25°C	-	-	10	
		T _j = 125°C	-	-	10	

CONVERTER PART

Symbol	Parameter	Condition	Limits			Unit
			Min.	Typ.	Max.	
I _{RRM}	Repetitive reverse current	V _R =V _{RRM} , T _j =125°C	-	-	7.0	mA
V _F	Forward voltage drop	I _F =25A	-	1.1	1.4	V

CONTROL (PROTECTION) PART

Symbol	Parameter	Condition	Limits			Unit	
			Min.	Typ.	Max.		
I _D	Circuit current	Total of V _{P1} -V _{NC} , V _{N1} -V _{NC}	V _D =15V, V _{IN} =0V	-	-	4.70	mA
			V _D =15V, V _{IN} =5V	-	-	4.70	
I _{DB}		Each part of V _{UFB} -V _{UFS} , V _{VFB} -V _{VFS} , V _{WFB} -V _{WFS}	V _D =V _{DB} =15V, V _{IN} =0V	-	-	0.55	
			V _D =V _{DB} =15V, V _{IN} =5V	-	-	0.55	
V _{SC(ref)}	Short circuit trip level	V _D = 15V (Note 4)	0.455	0.480	0.505	V	
UV _{DBt}	Control supply under-voltage protection(UV) for P-side of inverter part	Trip level	10.0	-	12.0	V	
UV _{DBr}			Reset level	10.5	-	12.5	V
UV _{Dt}	Control supply under-voltage protection(UV) for N-side of inverter part	Trip level	10.3	-	12.5	V	
UV _{Dr}			Reset level	10.8	-	13.0	V
V _{OT}	Temperature Output	Pull down R=5.1kΩ, LVIC Temperature=100°C (Note 5)	2.89	3.02	3.14	V	
V _{FOH}	Fault output voltage	V _{SC} = 0V, F _O terminal pulled up to 5V by 10kΩ	4.9	-	-	V	
V _{FOL}		V _{SC} = 1V, I _{FO} = 1mA	-	-	0.95	V	
t _{FO}	Fault output pulse width	In case of C _{F0} =22nF (Note 6,7)	1.6	2.4	-	ms	
I _{IN}	Input current	V _{IN} = 5V	0.70	1.00	1.50	mA	
V _{th(on)}	ON threshold voltage	Applied between U _P ,V _P ,W _P ,U _N , V _N , W _N -V _{NC}	-	-	3.5	V	
V _{th(off)}	OFF threshold voltage		0.8	-	-		
V _F	Bootstrap Di forward voltage	I _F =10mA including voltage drop by limiting resistor (Note 8)	-	0.9	1.3	V	
R	Built-in limiting resistance	Included in bootstrap Di	16	20	24	Ω	

Note 4 : SC protection works only for N-side IGBT in inverter part. Please select the external shunt resistance such that the SC trip-level is less than 1.7 times of the current rating.

5 : DIIPM don't shutdown IGBTs and output fault signal automatically when temperature rises excessively. When temperature exceeds the protective level that user defined, controller (MCU) should stop the DIIPM. Temperature of LVIC vs. VOT output characteristics is described in Fig. 3.

6 : Fault signal Fo outputs when SC or UV protection works for N-side IGBT in inverter part. The fault output pulse-width t_{FO} is depended on the capacitance value of C_{F0} (C_{F0} = t_{FO} × 9.1 × 10⁻⁶ [F]).

7 : UV protection also works for P-side IGBT in inverter part without fault signal Fo.

8 : The characteristics of bootstrap Di is described in Fig.2.

< DIIPM >
PSS25NC1FT
 TRANSFER MOLDING TYPE
 INSULATED TYPE

Fig. 2 Characteristics of Bootstrap Di V_F - I_F curve (@ $T_a=25^\circ\text{C}$) Including Voltage Drop by Limiting Resistor (Right chart is enlarged chart.)

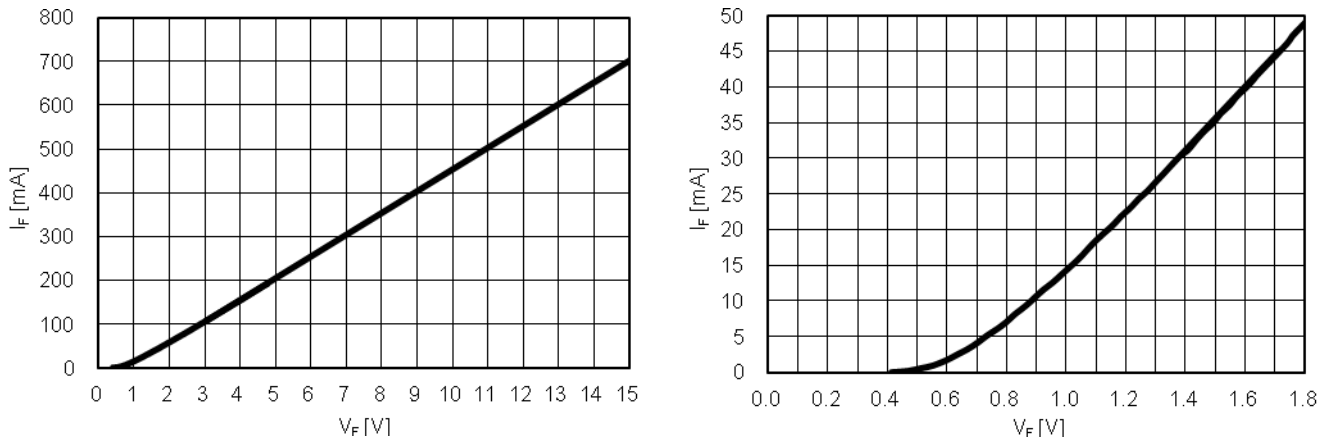
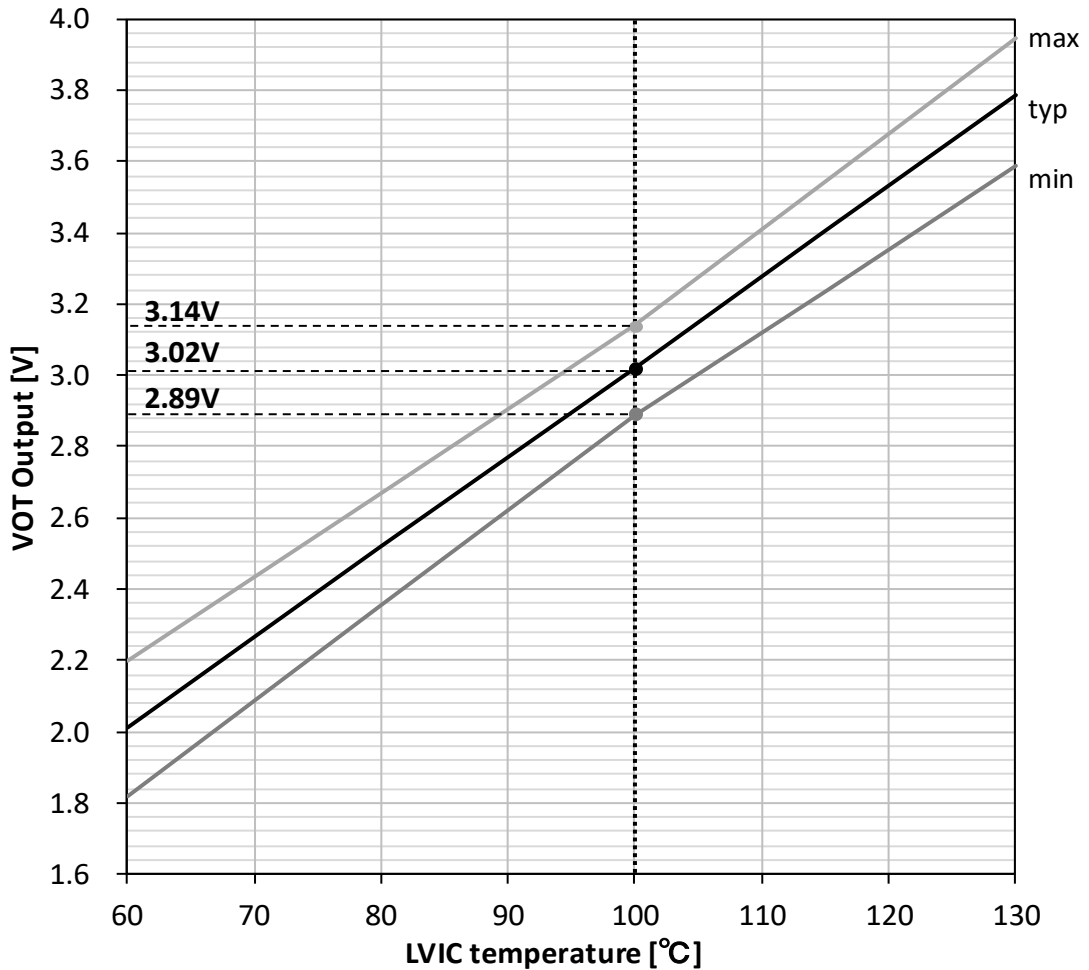
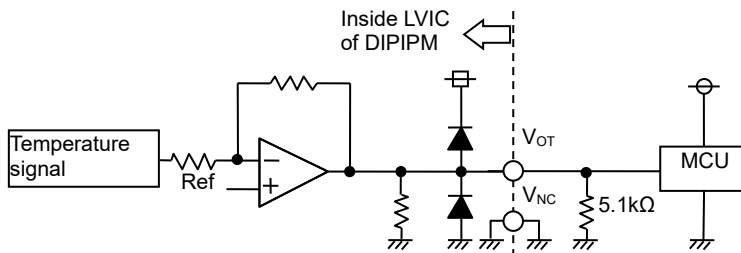

Fig. 3 Temperature of LVIC vs. V_{OT} Output Characteristics



< DIIPM >
PSS25NC1FT
 TRANSFER MOLDING TYPE
 INSULATED TYPE

Fig. 4 Pattern Wiring Around the Analog Voltage Output Circuit [V_{OT} terminal]



- (1) V_{OT} outputs the analog signal that is amplified signal of temperature detecting element on LVIC by inverting amplifier.
- (2) It is recommended to insert 5kΩ (5.1kΩ is recommended) pull down resistor for getting linear output characteristics at low temperature below room temperature. When the pull down resistor is inserted between V_{OT} and V_{NC} (control GND), the extra circuit current, which is calculated approximately by V_{OT} output voltage divided by pull down resistance, flows as LVIC circuit current continuously. In the case of using V_{OT} for detecting high temperature over room temperature only, it is unnecessary to insert the pull down resistor.
- (3) In the case of not using V_{OT} , leave V_{OT} output NC (No Connection).

Please also refer the application note for DIIPM+ series about the usage of V_{OT} .

MECHANICAL CHARACTERISTICS AND RATINGS

Parameter	Condition		Limits			Unit
			Min.	Typ.	Max.	
Mounting torque	Mounting screw : M4 (Note 9)	Recommended 1.18N·m	0.98	1.18	1.47	N·m
Terminal pulling strength	20N load	JEITA-ED-4701	10	—	—	s
Terminal bending strength	90deg bending with 10N load	JEITA-ED-4701	2	—	—	times
Weight			—	40	—	g
Heat radiation part flatness		(Note 10)	-50	—	+100	μm

Note 9: Plain washers (ISO 7089-7094) are recommended.

Note 10: Measurement positions of heat radiation part flatness are as below. (Dimension:mm)

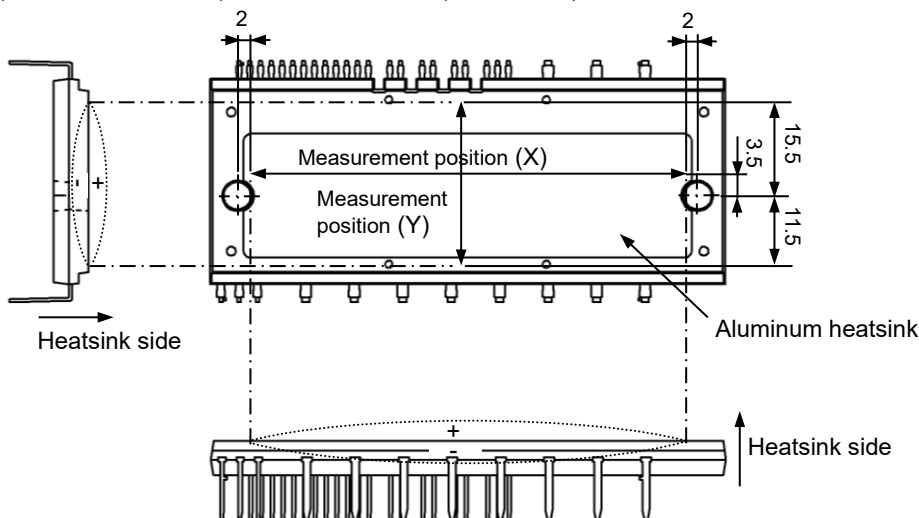

PSS25NC1FT

TRANSFER MOLDING TYPE
INSULATED TYPE

RECOMMENDED OPERATION CONDITIONS

Symbol	Parameter	Condition	Limits			Unit	
			Min.	Typ.	Max.		
V_{CC}	Supply voltage	Applied between P-NU, NV, NW	0	600	800	V	
V_D	Control supply voltage	Applied between $V_{P1}-V_{NC}, V_{N1}-V_{NC}$	13.5	15.0	16.5	V	
V_{DB}	Control supply voltage	Applied between $V_{UFB}-V_{UFS}, V_{VFB}-V_{VFS}, V_{WFB}-V_{WFS}$	13.0	15.0	18.5	V	
$\Delta V_D, \Delta V_{DB}$	Control supply variation		-1	-	1	V/ μ s	
t_{dead}	Arm shoot-through blocking time	For each input signal	3.0	-	-	μ s	
f_{PWM}	PWM input frequency	$T_C \leq 100^\circ\text{C}, T_J \leq 125^\circ\text{C}$	-	-	20	kHz	
PWIN(on)	Minimum input pulse width	$I_C \leq 1.7$ times of rated current (Note 11)	1.5	-	-	μ s	
PWIN(off)		$0 \leq V_{CC} \leq 800\text{V}, 13.5 \leq V_D \leq 16.5\text{V},$ $13.0 \leq V_{DB} \leq 18.5\text{V}, -20 \leq T_C \leq 100^\circ\text{C},$ N line wiring inductance less than 10nH (Note 12)	Less than rated current	3.0	-		-
			From rated current to 1.7 times of rated current	3.5	-		-
V_{NC}	V_{NC} variation	Between $V_{NC}-NU, NV, NW$ (including surge)	-5.0	-	+5.0	V	
T_J	Junction temperature		-20	-	125	$^\circ\text{C}$	

Note 11: DIIPM might not make response if the input signal pulse width is less than PWIN(on).

Note 12: DIIPM might make no response or delayed response (P-side IGBT only) for the input signal with off pulse width less than PWIN(off). Please refer below figure about delayed response.

About Delayed Response Against Shorter Input Off Signal Than PWIN(off) (P side only)

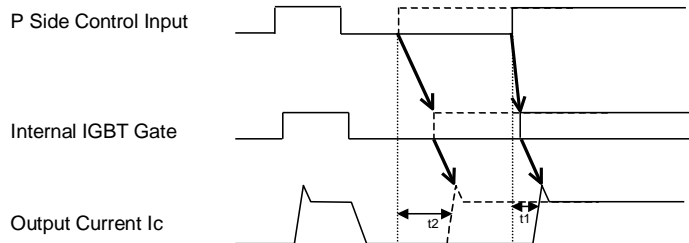

Real line···off pulse width>PWIN(off); turn on time t_1
 Broken line···off pulse width<PWIN(off); turn on time t_2

< DIIPM >
PSS25NC1FT
TRANSFER MOLDING TYPE
INSULATED TYPE

Fig. 5 Timing Charts of The DIIPM Protective Functions

[A] Short-Circuit Protection (N-side only with the external shunt resistor and RC filter)

- a1. Normal operation: IGBT ON and outputs current.
- a2. Short circuit current detection (SC trigger)
 (It is recommended to set RC time constant 1.5~2.0 μ s so that IGBT shut down within 2.0 μ s when SC.)
- a3. All N-side IGBT's gates are hard interrupted.
- a4. All N-side IGBTs turn OFF.
- a5. LVIC starts outputting fault signal (fault signal output time is controlled by external capacitor C_{FO})
- a6. Input = "L": IGBT OFF
- a7. Fo finishes output, but IGBTs don't turn on until inputting next ON signal (L \rightarrow H).
- (IGBT of each phase can return to normal state by inputting ON signal to each phase.)
- a8. Normal operation: IGBT ON and outputs current.

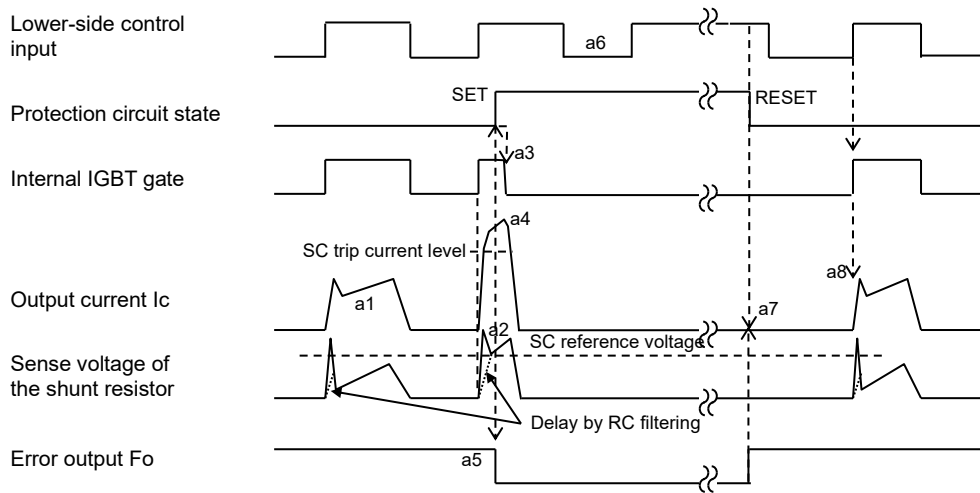

[B] Under-Voltage Protection (N-side, UV_D)

- b1. Control supply voltage V_D exceeds under voltage reset level (UV_{Dr}), but IGBT turns ON by next ON signal (L \rightarrow H).
 (IGBT of each phase can return to normal state by inputting ON signal to each phase.)
- b2. Normal operation: IGBT ON and outputs current.
- b3. V_D level drops to under voltage trip level. (UV_{Dt})
- b4. All N-side IGBTs turn OFF in spite of control input condition.
- b5. Fo outputs for the period set by external capacitor C_{FO} , but output is extended during V_D keeps below UV_{Dr} .
- b6. V_D level reaches UV_{Dr} .
- b7. Normal operation: IGBT ON and outputs current.

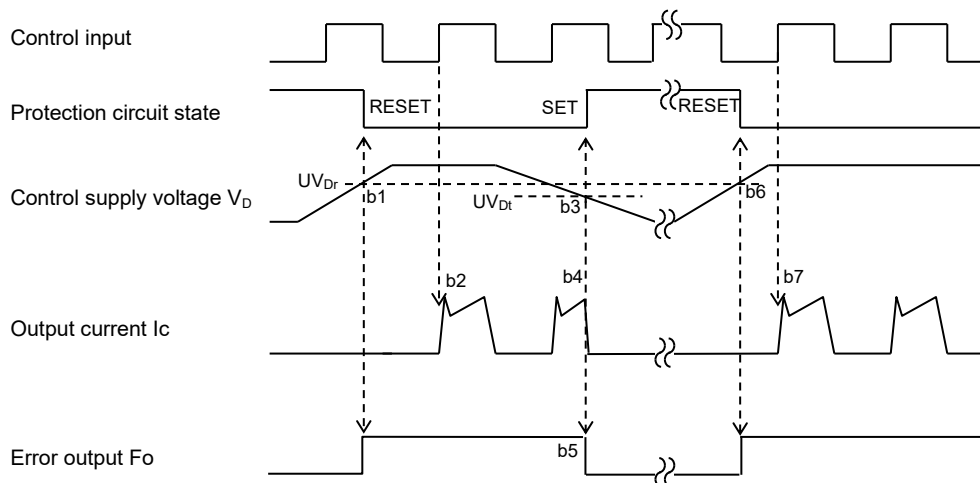

PSS25NC1FT

TRANSFER MOLDING TYPE
INSULATED TYPE

[C] Under-Voltage Protection (P-side, UV_{DB})

- c1. Control supply voltage V_{DB} rises. After the voltage reaches under voltage reset level UV_{DBr} , IGBT turns on by next ON signal (L→H).
- c2. Normal operation: IGBT ON and outputs current.
- c3. V_{DB} level drops to under voltage trip level (UV_{DBt}).
- c4. IGBT of the correspond phase only turns OFF in spite of control input signal level, but there is no F_o signal output.
- c5. V_{DB} level reaches UV_{DBr} .
- c6. Normal operation: IGBT ON and outputs current.

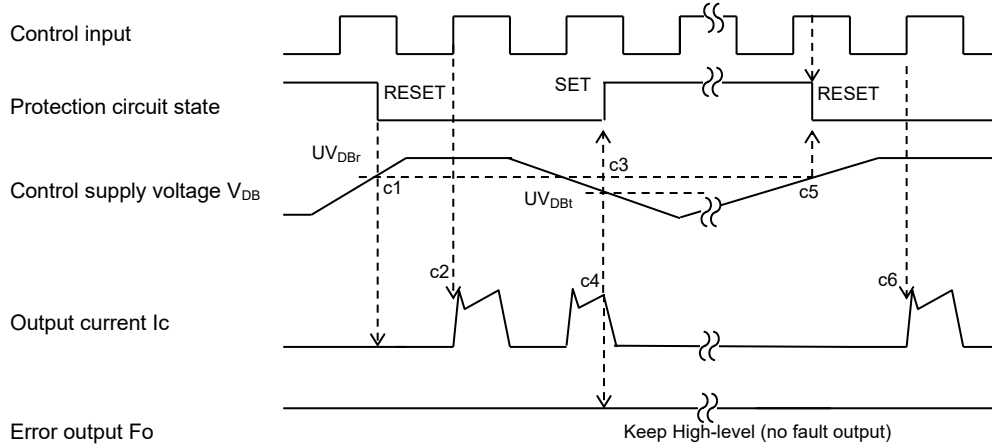

< DIIPM >
PSS25NC1FT
 TRANSFER MOLDING TYPE
 INSULATED TYPE

Fig. 6 Example of Application Circuit

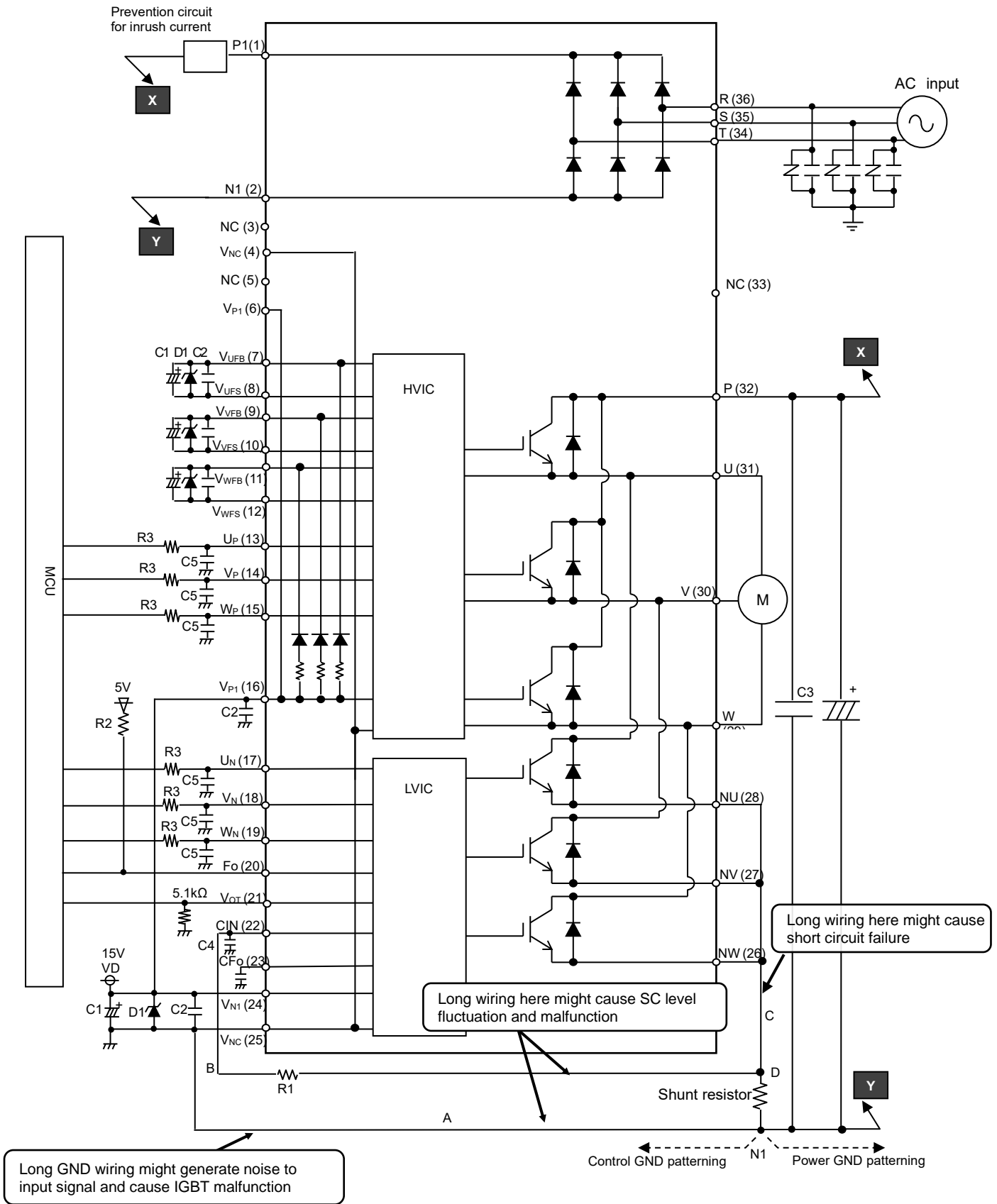

Note for the previous application circuit

- (1) If control GND is connected with power GND by common broad pattern, it may cause malfunction by power GND fluctuation. It is recommended to connect control GND and power GND at only a point N1 (near the terminal of shunt resistor).
- (2) It is recommended to insert a Zener diode D1(24V/1W) between each pair of control supply terminals to prevent surge destruction.
- (3) To prevent surge destruction, the wiring between the smoothing capacitor and the P, N1 terminals should be as short as possible. Generally a 0.1-0.22μF snubber capacitor C3 between the P-N1 terminals is recommended.
- (4) R1, C4 of RC filter for preventing protection circuit malfunction is recommended to select tight tolerance, temp-compensated type. The time constant R1C4 should be set so that SC current is shut down within 2μs. (1.5μs~2μs is recommended generally.) SC interrupting time might vary with the wiring pattern, so the enough evaluation on the real system is necessary.
- (5) To prevent malfunction, the wiring of A, B, C should be as short as possible.
- (6) The point D at which the wiring to CIN filter is divided should be near the terminal of shunt resistor. NU, NV, NW terminals should be connected each other at near those three terminals when it is used by one shunt operation. Low inductance SMD type with tight tolerance, temp-compensated type is recommended for shunt resistor.
- (7) All capacitors should be mounted as close to the terminals as possible. (C1: good temperature, frequency characteristic electrolytic type and C2:0.01μ-2μF, good temperature, frequency and DC bias characteristic ceramic type are recommended.)
- (8) Input logic is High-active. There is a 3.3kΩ(min.) pull-down resistor in the input circuit of IC. To prevent malfunction, the input wiring should be as short as possible. When using RC coupling, make the input signal level meet the turn-on and turn-off threshold voltage.
- (9) Fo output is open drain type. Fo output will be max 0.95V(@I_{FO}=1mA,25°C), so it should be pulled up to MCU or control power supply (e.g. 5V,15V) by a resistor that makes I_{FOup} to 1mA. (In the case of pulled up to 5V, 10kΩ is recommended.) About driving opto coupler by Fo output, please refer the application note of this series.
- (10) Fo pulse width can be set by the capacitor connected to CFO terminal. C_{FO}(F) = 9.1 x 10⁻⁶ x t_{FO} (Required Fo pulse width).
- (11) If high frequency noise superimposed to the control supply line, IC malfunction might happen and cause DIIPIM erroneous operation. To avoid such problem, line ripple voltage should meet dV/dt ≤ +/-1V/μs, V_{ripple} ≤ 2Vp-p.
- (12) For DIIPIM, it isn't recommended to drive same load by parallel connection with other phase IGBT or other DIIPIM.
- (13) No.4 and No.25 V_{NC} terminals (GND terminal for control supply) are connected mutually inside of DIIPIM+ and also No.6 and No.16 V_{P1} terminals are connected mutually inside, please connect either No.4 or No.25 terminal to GND and also connect either No.6 or No.16 terminal to supply and make the unused terminal leave no connection.

Fig. 7 MCU I/O Interface Circuit

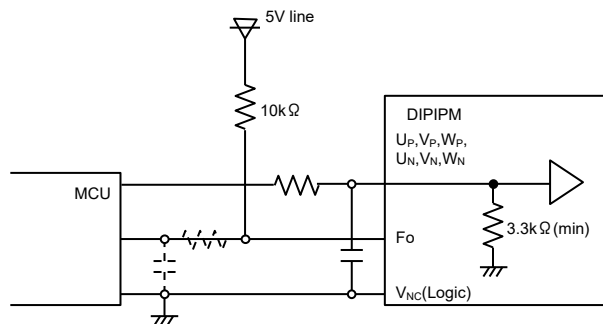

Note)

Design for input RC filter depends on the PWM control scheme used in the application and the wiring impedance of the printed circuit board. But because noisier in the application for 1200V rating, it is strongly recommended to insert RC filter. (Time constant: over 100ns. e.g. 100Ω, 1000pF)

The DIIPIM input signal interface integrates a min. 3.3kΩ pull-down resistor. Therefore, when using RC filter, be careful to satisfy turn-on threshold voltage requirement.

Fo output is open drain type. It should be pulled up to the positive side of 5V or 15V power supply with the resistor that limits Fo sink current I_{FO} under 1mA. In the case of pulling up to 5V supply, over 5.1kΩ is needed. (10kΩ is recommended.)

Fig. 8 Pattern Wiring Around the Shunt Resistor

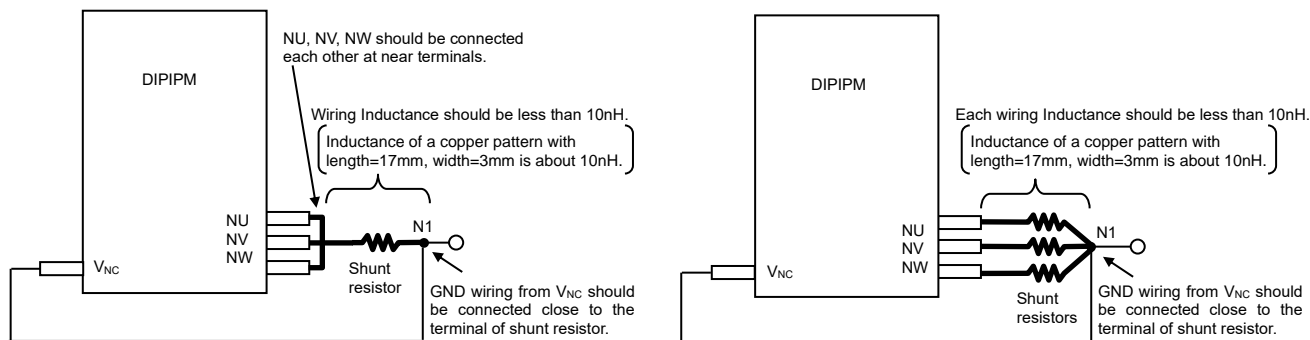

Low inductance shunt resistor like surface mounted (SMD) type is recommended.

Fig. 9 External SC Protection Circuit with Using Three Shunt Resistors

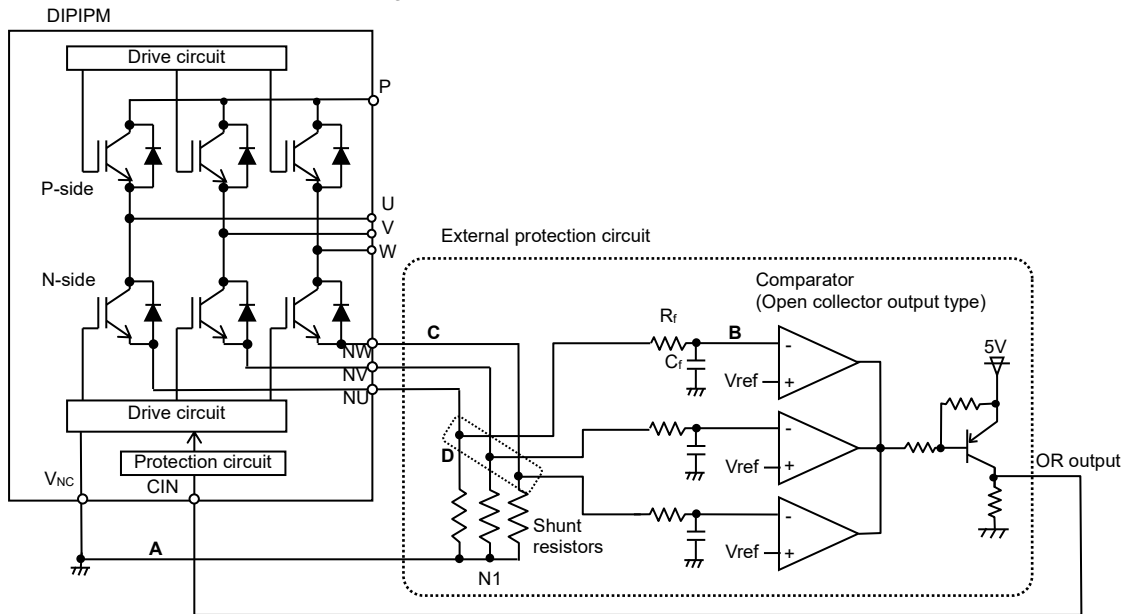

- (1) It is necessary to set the time constant $R_r C_f$ of external comparator input so that IGBT stop within $2\mu\text{s}$ when short circuit occurs. SC interrupting time might vary with the wiring pattern, comparator speed and so on.
- (2) The threshold voltage V_{ref} should be set up the same rating of short circuit trip level ($V_{sc(ref)}$ typ. 0.48V).
- (3) Select the external shunt resistance so that SC trip-level is less than specified value.
- (4) To avoid malfunction, the wiring A, B, C should be as short as possible.
- (5) The point D at which the wiring to comparator is divided should be near the terminal of shunt resistor.
- (6) OR output high level should be over 0.505V (=maximum $V_{sc(ref)}$).
- (7) GND of Comparator, V_{ref} circuit and C_f should be not connected to noisy power GND but to control GND wiring.

PSS25NC1FT

TRANSFER MOLDING TYPE
INSULATED TYPE

Fig. 10 PCB through-hole pattern

The recommended through-hole positions and diameters layout are shown.

Dimensions in mm

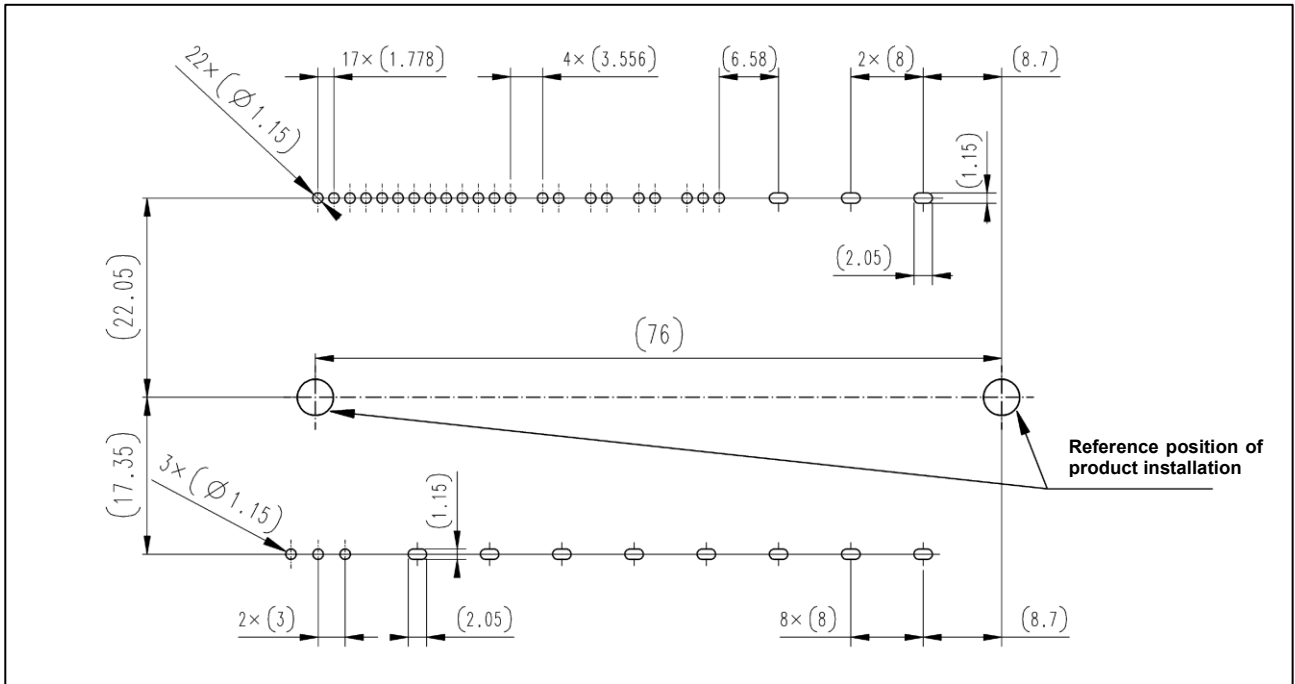

PSS25NC1FT

TRANSFER MOLDING TYPE
INSULATED TYPE

Fig. 11 Package Outlines

Dimensions in mm

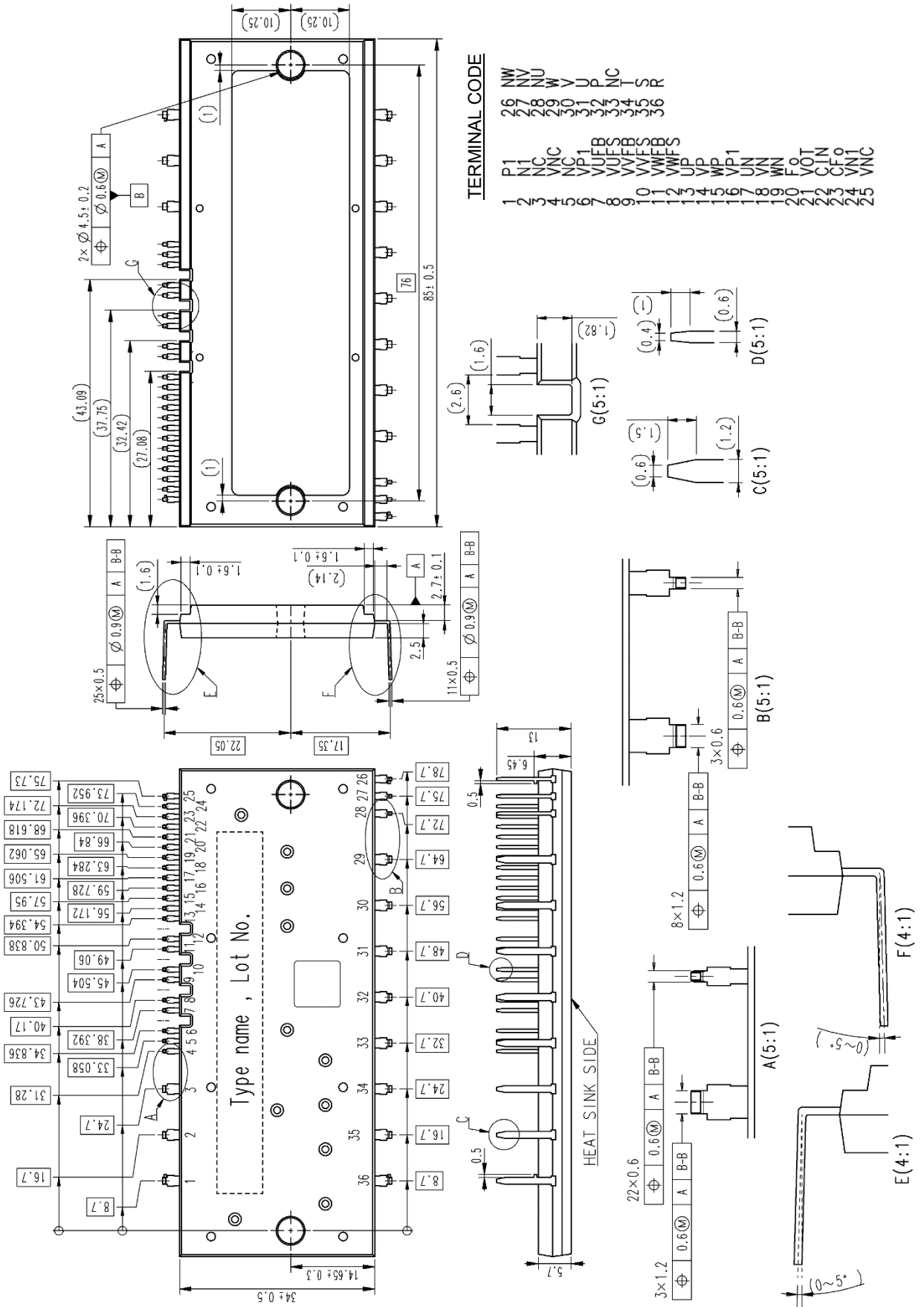

Important Notice

The information contained in this datasheet shall in no event be regarded as a guarantee of conditions or characteristics. This product has to be used within its specified maximum ratings, and is subject to customer's compliance with any applicable legal requirement, norms and standards.

Except as otherwise explicitly approved by Mitsubishi Electric Corporation in a written document signed by authorized representatives of Mitsubishi Electric Corporation, our products may not be used in any applications where a failure of the product or any consequences of the use thereof can reasonably be expected to result in personal injury.

In usage of power semiconductor, there is always the possibility that trouble may occur with them by the reliability lifetime such as Power Cycle, Thermal Cycle or others, or when used under special circumstances (e.g. condensation, high humidity, dusty, salty, highlands, environment with lots of organic matter / corrosive gas / explosive gas, or situations which terminals of semiconductor products receive strong mechanical stress). Therefore, please pay sufficient attention to such circumstances. Further, depending on the technical requirements, our semiconductor products may contain environmental regulation substances, etc. If there is necessity of detailed confirmation, please contact our nearest sales branch or distributor.

The contents or data contained in this datasheet are exclusively intended for technically trained staff. Customer's technical departments should take responsibility to evaluate the suitability of Mitsubishi Electric Corporation product for the intended application and the completeness of the product data with respect to such application. In the customer's research and development, please evaluate it not only with a single semiconductor product but also in the entire system, and judge whether it's applicable. As required, pay close attention to the safety design by installing appropriate fuse or circuit breaker between a power supply and semiconductor products to prevent secondary damage. Please also pay attention to the application note and the related technical information.

Keep safety first in your circuit designs!

Mitsubishi Electric Corporation puts the maximum effort into making semiconductor products better and more reliable, but there is always the possibility that trouble may occur with them. Trouble with semiconductors may lead to personal injury, fire or property damage. Remember to give due consideration to safety when making your circuit designs, with appropriate measures such as (i) placement of substitutive, auxiliary circuits, (ii) use of non-flammable material or (iii) prevention against any malfunction or mishap.

Notes regarding these materials

- These materials are intended as a reference to assist our customers in the selection of the Mitsubishi Electric Semiconductor product best suited to the customer's application; they do not convey any license under any intellectual property rights, or any other rights, belonging to Mitsubishi Electric Corporation or a third party.
- Mitsubishi Electric Corporation assumes no responsibility for any damage, or infringement of any third-party's rights, originating in the use of any product data, diagrams, charts, programs, algorithms, or circuit application examples contained in these materials.
- All information contained in these materials, including product data, diagrams, charts, programs and algorithms represents information on products at the time of publication of these materials, and are subject to change by Mitsubishi Electric Corporation without notice due to product improvements or other reasons. It is therefore recommended that customers contact Mitsubishi Electric Corporation or an authorized Mitsubishi Electric Semiconductor product distributor for the latest product information before purchasing a product listed herein.
The information described here may contain technical inaccuracies or typographical errors. Mitsubishi Electric Corporation assumes no responsibility for any damage, liability, or other loss rising from these inaccuracies or errors.
Please also pay attention to information published by Mitsubishi Electric Corporation by various means, including the Mitsubishi Electric Semiconductor home page (<http://www.MitsubishiElectric.com/semiconductors/>).
- When using any or all of the information contained in these materials, including product data, diagrams, charts, programs, and algorithms, please be sure to evaluate all information as a total system before making a final decision on the applicability of the information and products. Mitsubishi Electric Corporation assumes no responsibility for any damage, liability or other loss resulting from the information contained herein.
- Mitsubishi Electric Corporation semiconductors are not designed or manufactured for use in a device or system that is used under circumstances in which human life is potentially at stake. Please contact Mitsubishi Electric Corporation or an authorized Mitsubishi Electric Semiconductor product distributor when considering the use of a product contained herein for any specific purposes, such as apparatus or systems for transportation, vehicular, medical, aerospace, nuclear, or undersea repeater use.
- The prior written approval of Mitsubishi Electric Corporation is necessary to reprint or reproduce in whole or in part these materials.
- If these products or technologies are subject to the Japanese export control restrictions, they must be exported under a license from the Japanese government and cannot be imported into a country other than the approved destination.
Any diversion or re-export contrary to the export control laws and regulations of Japan and/or the country of destination is prohibited.
- Please contact Mitsubishi Electric Corporation or an authorized Mitsubishi Electric Semiconductor product distributor for further details on these materials or the products contained therein.