

< DIIPM >

# PSS50NE1CT

TRANSFER MOLDING TYPE  
INSULATED TYPE

## OUTLINE

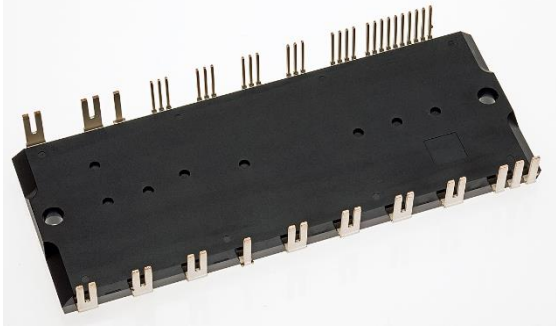

## MAIN FUNCTION

CI (Converter + Inverter) type IPM

- 3-phase Inverter
- 3-phase Converter

## RATING

- Inverter part : 50A/1200V (CSTBT)

## APPLICATION

- AC400V three phase motor inverter drive

## INTEGRATED DRIVE, PROTECTION AND SYSTEM CONTROL FUNCTIONS

- For P-side : Drive circuit, High voltage high-speed level shifting, Control supply under-voltage (UV) protection
- For N-side : Drive circuit, Control supply under-voltage protection (UV), Short circuit protection (SC)
- Fault signaling : Corresponding to SC fault (N-side IGBT), UV fault (N-side supply)
- Temperature output : Outputting LVIC temperature by analog signal
- Input interface : 3.3, 5V line (High Active)
- UL Recognized : UL1557 File E323585

## INTERNAL CIRCUIT

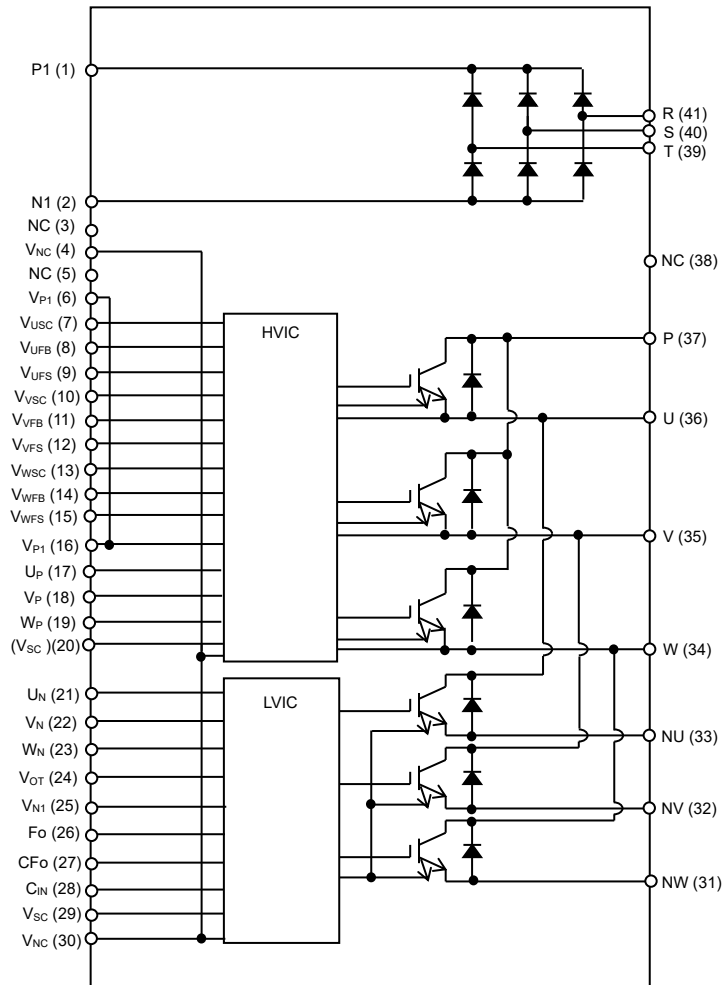

\*It is necessary to short the  $V_{USC}-V_{UFS}$ ,  $V_{VSC}-V_{VFS}$ ,  $V_{WSC}-V_{WFS}$  pins.

# PSS50NE1CT

TRANSFER MOLDING TYPE  
INSULATED TYPE

## MAXIMUM RATINGS (T<sub>j</sub> = 25°C, unless otherwise noted)

### INVERTER PART

Symbol	Parameter	Condition	Ratings	Unit
V <sub>CC</sub>	Supply voltage	Applied between P-NU,NV,NW	800	V
V <sub>CC(surge)</sub>	Supply voltage (surge)	Applied between P-NU,NV,NW	1000	V
V <sub>CES</sub>	Collector-emitter voltage		1200	V
±I <sub>C</sub>	Each IGBT collector current	T <sub>C</sub> = 25°C (Note 1)	50	A
±I <sub>CP</sub>	Each IGBT collector current (peak)	T <sub>C</sub> = 25°C, up to 1ms	75	A
T <sub>jop</sub>	Junction temperature	Continuous operation (Note 2)	-30~+150	°C
T <sub>jmax</sub>	Maximum Junction temperature	Instantaneous event(overload)	175	°C

Note1: Pulse width and period are limited due to junction temperature.

Note2: The maximum junction temperature rating is 175°C. But for safe operation, it is recommended to limit the average junction temperature up to 150°C.

### CONVERTER PART

Symbol	Parameter	Condition	Ratings	Unit
V <sub>RRM</sub>	Repetitive peak reverse voltage		1600	V
I <sub>O</sub>	DC output current	3φ rectifying circuit	50	A
I <sub>FSM</sub>	Surge forward current	Half sine at 60Hz, Peak value, Non-repetitive	532	A
I <sup>2</sup> t	I <sup>2</sup> t for fusing	Value for 1 cycle of surge current	1132	A <sup>2</sup> s
T <sub>j</sub>	Junction temperature	(Note 3)	-30~+150	°C

Note3: The maximum junction temperature rating is 150°C. But for safe operation, it is recommended to limit the average junction temperature up to 125°C.

### CONTROL (PROTECTION) PART

Symbol	Parameter	Condition	Ratings	Unit
V <sub>D</sub>	Control supply voltage	Applied between V <sub>P1</sub> -V <sub>PC</sub> , V <sub>N1</sub> -V <sub>NC</sub>	20	V
V <sub>DB</sub>	Control supply voltage	Applied between V <sub>UFB</sub> -V <sub>UFS</sub> , V <sub>VFB</sub> -V <sub>VFS</sub> , V <sub>WFB</sub> -V <sub>WFS</sub>	20	V
V <sub>IN</sub>	Input voltage	Applied between U <sub>P</sub> , V <sub>P</sub> , W <sub>P</sub> -V <sub>PC</sub> , U <sub>N</sub> , V <sub>N</sub> , W <sub>N</sub> -V <sub>NC</sub>	-0.5~V <sub>D</sub> +0.5	V
V <sub>FO</sub>	Fault output supply voltage	Applied between F <sub>O</sub> -V <sub>NC</sub>	-0.5~V <sub>D</sub> +0.5	V
I <sub>FO</sub>	Fault output current	Sink current at F <sub>O</sub> terminal	5	mA
V <sub>SC</sub>	Current sensing input voltage	Applied between CIN-V <sub>NC</sub>	-0.5~V <sub>D</sub> +0.5	V

### TOTAL SYSTEM

Symbol	Parameter	Condition	Ratings	Unit
V <sub>CC(PROT)</sub>	Self protection supply voltage limit (Short circuit protection capability)	V <sub>D</sub> = 13.5~16.5V, Inverter Part T <sub>j</sub> = 150°C, non-repetitive, up to 2μs	800	V
T <sub>C</sub>	Module case operation temperature	T <sub>C</sub> measurement point is defined in Fig.1.	-30~+125	°C
T <sub>stg</sub>	Storage temperature		-40~+125	°C
V <sub>iso</sub>	Isolation voltage	60Hz, Sinusoidal, AC 1min, between connected all pins and heat sink plate	2500	V <sub>rms</sub>

Fig. 1: T<sub>C</sub> MEASUREMENT POINT

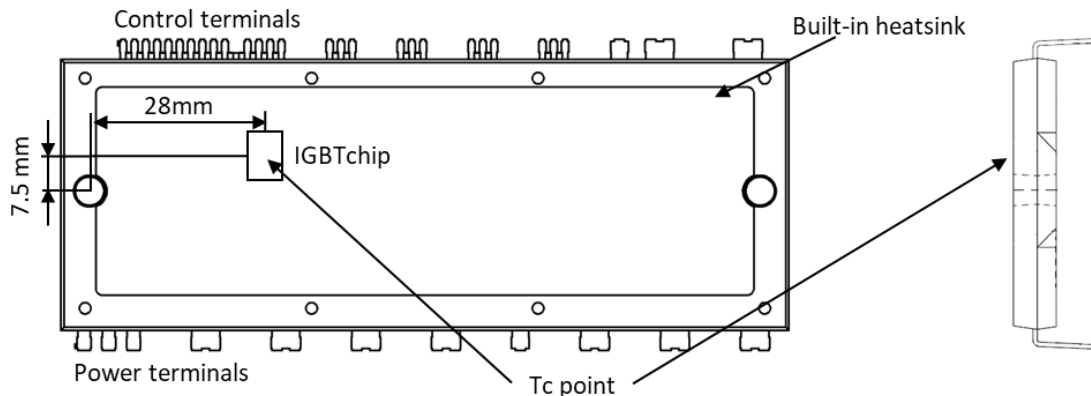

# PSS50NE1CT

TRANSFER MOLDING TYPE  
INSULATED TYPE

## THERMAL RESISTANCE

Symbol	Parameter	Condition	Limits			Unit
			Min.	Typ.	Max.	
$R_{th(j-c)Q}$	Junction to case thermal resistance (Note 4)	Inverter IGBT part (per 1/6 module)	-	-	0.65	K/W
$R_{th(j-c)F}$		Inverter FWDi part (per 1/6 module)	-	-	1.10	K/W
$R_{th(j-c)R}$		Converter part (per 1/6module)	-	-	1.00	K/W

Note 4: Grease with good thermal conductivity and long-term endurance should be applied evenly with about +100µm~+200µm on the contacting surface of DIIPM and heat-sink. The contacting thermal resistance between DIIPM case and heat sink  $R_{th(c-f)}$  is determined by the thickness and the thermal conductivity of the applied grease. For reference,  $R_{th(c-f)}$  (per 1chip) is about 0.25K/W when the grease thickness is 20µm and the thermal conductivity is 1.0W/m·K

## ELECTRICAL CHARACTERISTICS ( $T_j = 25^\circ\text{C}$ , unless otherwise noted)

### INVERTER PART

Symbol	Parameter	Condition	Limits			Unit
			Min.	Typ.	Max.	
$V_{CE(sat)}$	Collector-emitter saturation voltage	$V_D=V_{DB}=15\text{V}$ , $V_{IN}=5\text{V}$ , $I_C=50\text{A}$	$T_j=25^\circ\text{C}$		1.90	V
		$T_j=125^\circ\text{C}$		2.30		
$V_{EC}$	FWDi forward voltage	$V_{IN}=0\text{V}$ , $-I_C=50\text{A}$	-	1.85	2.40	V
$t_{on}$	Switching times	$V_{CC}=600\text{V}$ , $V_D=V_{DB}=15\text{V}$ $I_C=50\text{A}$ , $T_j=125^\circ\text{C}$ , $V_{IN}=0\leftrightarrow 5\text{V}$ Inductive Load (upper-lower arm)	1.40	2.30	3.30	µs
$t_{C(on)}$			-	0.40	0.85	µs
$t_{off}$			-	2.70	3.80	µs
$t_{C(off)}$			-	0.30	0.95	µs
$t_{rr}$			-	0.30	-	µs
$I_{CES}$	Collector-emitter cut-off current	$V_{CE}=V_{CES}$	-	-	1	mA

### CONVERTER PART

Symbol	Parameter	Condition	Limits			Unit
			Min.	Typ.	Max.	
$I_{RRM}$	Repetitive reverse current	$V_R=V_{RRM}$	-	-	0.5	mA
$V_F$	Forward voltage drop	$I_F=50\text{A}$	-	1.20	1.65	V

### CONTROL (PROTECTION) PART

Symbol	Parameter	Condition	Limits			Unit	
			Min.	Typ.	Max.		
$I_D$	Circuit current	Total of $V_{P1}-V_{PC}$ , $V_{N1}-V_{NC}$	$V_D=15\text{V}$ , $V_{IN}=0\text{V}$	-	-	4.70	mA
			$V_D=15\text{V}$ , $V_{IN}=5\text{V}$	-	-	4.70	
$I_{DB}$	Each part of $V_{UFB}-V_{UFS}$ , $V_{VFB}-V_{VFS}$ , $V_{WFB}-V_{WFS}$		$V_{DB}=15\text{V}$ , $V_{IN}=0\text{V}$	-	-	2.40	
			$V_{DB}=15\text{V}$ , $V_{IN}=5\text{V}$	-	-	2.40	
$I_{SC}$	Short circuit trip level	$R_s=46.4\Omega (\pm 1\%)$ , Not connecting outer shunt resistors to NU,NV,NW terminals (Note 5)	75	-	-	A	
$UV_{DBt}$	P-side Control supply under-voltage protection(UV)		Trip level	10.0	-	12.3	V
$UV_{DBr}$			Reset level	10.4	-	12.9	V
$UV_{Dt}$	N-side Control supply under-voltage protection(UV)		Trip level	10.3	-	12.5	V
$UV_{Dr}$			Reset level	10.8	-	13.0	V
$V_{FOH}$	Fault output voltage	$V_{SC}=0\text{V}$ , $F_O$ terminal pulled up to 5V by 10kΩ	4.9	-	-	V	
$V_{FOL}$		$V_{SC}=1\text{V}$ , $I_{FO}=1\text{mA}$	-	-	0.95	V	
$t_{FO}$	Fault output pulse width	$C_{FO}=22\text{nF}$ (Note 6)	1.6	2.4	-	ms	
$I_{IN}$	Input current	$V_{IN}=5\text{V}$	0.7	1.0	1.5	mA	
$V_{th(on)}$	ON threshold voltage	Applied between $U_P$ , $V_P$ , $W_P-V_{NC}$ , $U_N$ , $V_N$ , $W_N-V_{NC}$	-	-	2.6	V	
$V_{th(off)}$	OFF threshold voltage		0.8	-	-	V	
$V_{OT}$	Temperature output	LVIC temperature=100°C, pull-down resistor=5.1kΩ (Note 7)	2.89	3.02	3.14	V	

Note 5: Short circuit protection detects sense current divided from main current at N-side IGBT only. In the case that outer shunt resistor is inserted into main current path, protection current level  $I_{sc}$  changes. For over-current protection by outside circuit, set the protection level under  $I_{CP}$ .

6: Fault signal is output when short circuit or N-side control supply under-voltage protection works. The fault output pulse-width  $t_{FO}$  depends on the capacitance of  $C_{FO}$ . ( $C_{FO}(\text{typ.}) = t_{FO} \times 9.1 \times 10^{-6}$  [F])

7: DIIPM doesn't shut down IGBTs and output fault signal automatically when temperature rises excessively. When temperature exceeds the protective level that user defined, controller (MCU) should stop immediately. Temperature of LVIC vs.  $V_{OT}$  output characteristics is described in Fig.2. These minimum and maximum curves are based on theoretical designed value excluding LVIC temperature=100°C limits.

# PSS50NE1CT

TRANSFER MOLDING TYPE  
INSULATED TYPE

Fig. 2 Temperature of LVIC vs.  $V_{OT}$  Output Characteristics

(These minimum and maximum curves are based on theoretical designed value excluding LVIC temperature=100°C limits.)

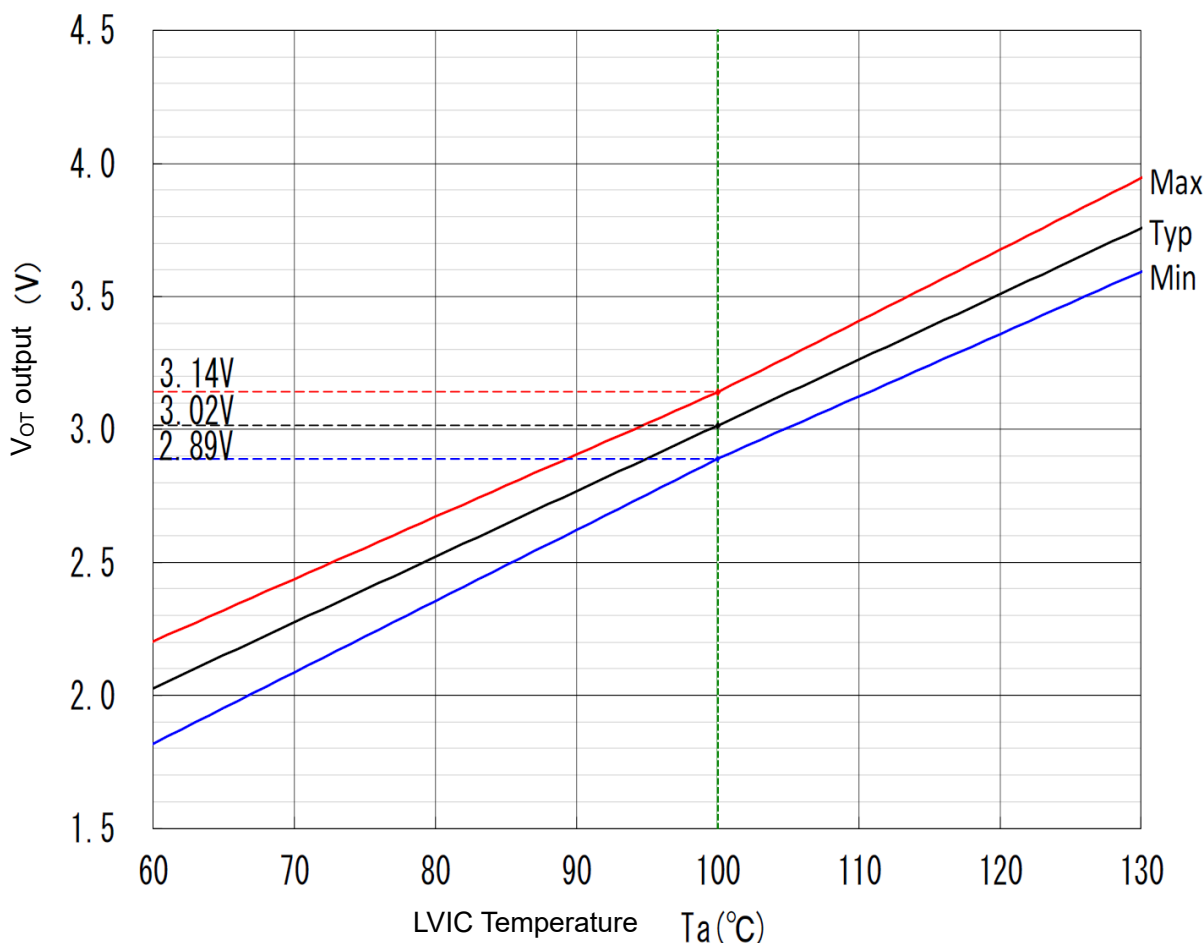
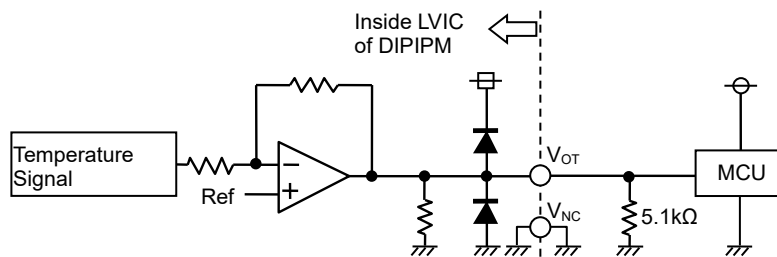

Fig. 3  $V_{OT}$  output circuit



- (1) It is recommended to insert 5.1kΩ pull down resistor for getting linear output characteristics at low temperature (below room temperature). When the pull down resistor is inserted between  $V_{OT}$  and  $V_{NC}$  (control GND), the extra circuit current, which is calculated approximately by  $V_{OT}$  output voltage divided by pull down resistance, flows as LVIC circuit current continuously. In the case of using  $V_{OT}$  for detecting only higher temperature than room temperature, it isn't necessary to insert the pull down resistor.
- (2) In the case of using  $V_{OT}$  with low voltage controller like 3.3V MCU,  $V_{OT}$  output might exceed control supply voltage 3.3V when temperature rises excessively. If system uses low voltage controller, it is recommended to insert a clamp Di between control supply of the controller and  $V_{OT}$  output for preventing over voltage destruction.
- (3) In the case of not using  $V_{OT}$ , leave  $V_{OT}$  output NC (No Connection).

Refer the application note for this product about the usage of  $V_{OT}$ .

# PSS50NE1CT

TRANSFER MOLDING TYPE  
INSULATED TYPE

## MECHANICAL CHARACTERISTICS AND RATINGS

Parameter	Condition	Reference	Limits			Unit
			Min.	Typ.	Max.	
Mounting torque	Mounting screw : M4 (Note 8)	JEITA-ED-4701 402 method II	0.98	1.18	1.47	N·m
Terminal strength pulling	Weight power terminal:40N control terminal:10N	JEITA-ED-4701 401 method I	10	-	-	s
Terminal strength bending	Load 10N, 90deg. bend	JEITA-ED-4701 401 method III	2	-	-	times
Weight			-	89	-	g
Heat radiation part flatness	(Note 9)		-50	-	130	μm

Note 8: Plain washers (ISO 7089~7094) are recommended.

Note 9: Measurement point of heat-sink flatness

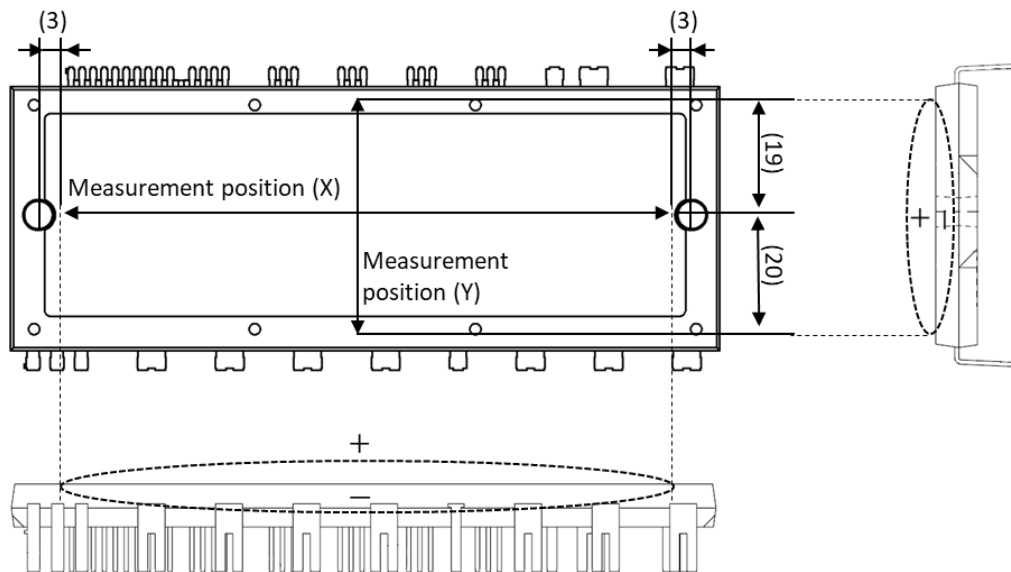

(Unit: mm)

## RECOMMENDED OPERATION CONDITIONS

Symbol	Parameter	Condition	Limits			Unit
			Min.	Typ.	Max.	
$V_{CC}$	Supply voltage	Applied between P-NU, NV, NW	300	600	800	V
$V_D$	Control supply voltage	Applied between $V_{P1}-V_{NC}$ , $V_{N1}-V_{NC}$	13.5	15.0	16.5	V
$V_{DB}$	Control supply voltage	Applied between $V_{UFB}-V_{UFS}$ , $V_{VFB}-V_{VFS}$ , $V_{WFB}-V_{WFS}$	13.0	15.0	18.5	V
$\Delta V_D, \Delta V_{DB}$	Control supply variation		-1	-	+1	V/μs
$t_{dead}$	Arm shoot-through blocking time	For each input signal	2.5	-	-	μs
$f_{PWM}$	PWM input frequency	$T_C \leq 125^\circ C$ , $T_I \leq 150^\circ C$	-	-	20	kHz
$V_{NC}$	$V_{NC}$ terminal voltage	Between $V_{NC}-NU$ , NV, NW (including surge)	-5.0	-	+5.0	V
$PWIN(on)$	Minimum input pulse width	(Note 10)	3.0	-	-	μs
$PWIN(off)$		(Note 11)	3.0	-	-	

Note 10 : DIIPM might not make response if the input signal pulse width is less than  $PWIN(on)$ .

Note 11 : DIIPM might make no response or delayed response (P-side IGBT only) for input pulse width less than  $PWIN(off)$ . Over rated collector current ( $I_c$ ) operation, DIIPM might make delayed response even if the input signal pulse width is  $PWIN(off)$  or more. The timing charts are described as below.

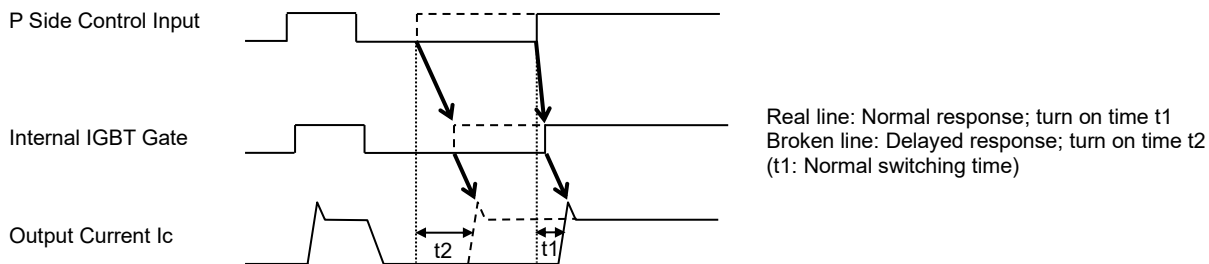

# PSS50NE1CT

TRANSFER MOLDING TYPE  
INSULATED TYPE

Fig. 4 Timing Charts of DIIPM Protective Functions

[A] Short-Circuit Protection (N-side only with the external sense resistor and RC filter)

- a1. Normal operation: IGBT ON and outputs current.
- a2. Short circuit current detection (SC trigger)  
(It is recommended to set RC time constant 1.5~2.0μs so that IGBT shut down within 2.0μs when SC occurs.)
- a3. All N-side IGBT's gates are hard interrupted.
- a4. All N-side IGBTs turn OFF.
- a5. F<sub>O</sub> outputs with a fixed pulse width determined by the external capacitor C<sub>F<sub>O</sub></sub>.
- a6. Input = "L": IGBT OFF
- a7. F<sub>o</sub> finishes output, but IGBTs don't turn on until inputting next ON signal (L→H).  
(IGBT of each phase can return to normal state by inputting ON signal to each phase.)
- a8. Normal operation: IGBT ON and outputs current.

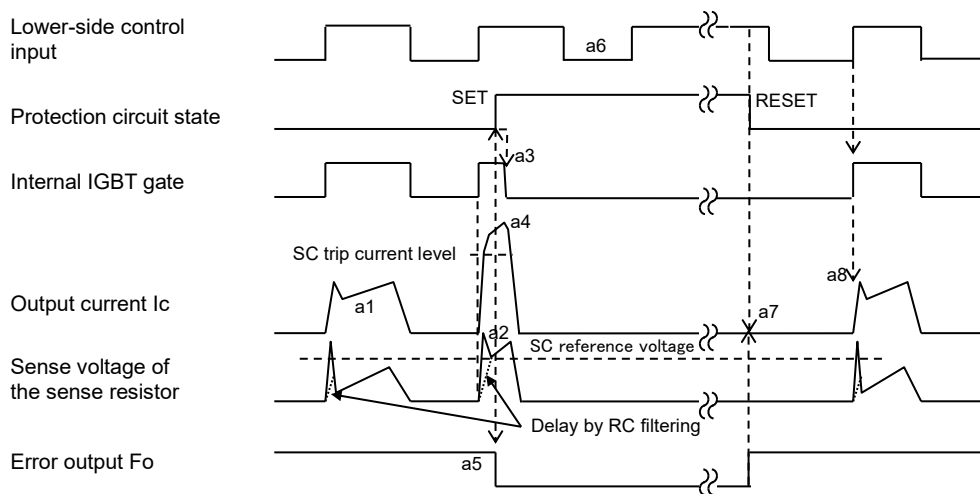

[B] Under-Voltage Protection (N-side, UV<sub>D</sub>)

- b1. Control supply voltage V<sub>D</sub> exceeds under voltage reset level (UV<sub>Dr</sub>), but IGBT turns ON by next ON signal (L→H).  
(IGBT of each phase can return to normal state by inputting ON signal to each phase.)
- b2. Normal operation: IGBT ON and outputs current.
- b3. V<sub>D</sub> level drops to under voltage trip level. (UV<sub>Dt</sub>).
- b4. All N-side IGBTs turn OFF in spite of control input condition.
- b5. F<sub>o</sub> outputs for the period determined by the capacitance C<sub>F<sub>O</sub></sub>, but output is extended during V<sub>D</sub> keeps below UV<sub>Dr</sub>.
- b6. V<sub>D</sub> level reaches UV<sub>Dr</sub>.
- b7. Normal operation: IGBT ON and outputs current by next ON signal (L→H).

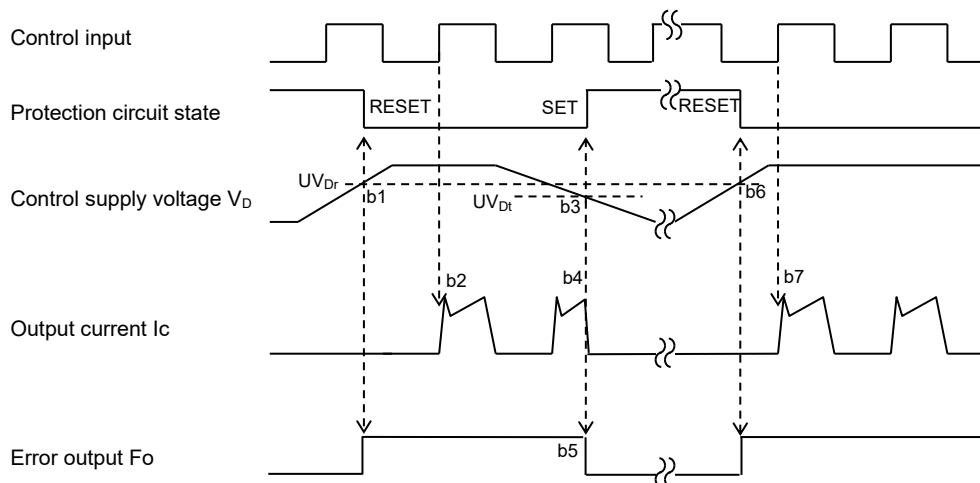

# PSS50NE1CT

TRANSFER MOLDING TYPE  
INSULATED TYPE

## [C] Under-Voltage Protection (P-side, $UV_{DB}$ )

- c1. Control supply voltage  $V_{DB}$  rises. After the voltage reaches under voltage reset level  $UV_{DBr}$ , IGBT turns on by next ON signal (L→H).
- c2. Normal operation: IGBT ON and outputs current.
- c3.  $V_{DB}$  level drops to under voltage trip level ( $UV_{DBt}$ ).
- c4. IGBT of corresponding phase only turns OFF in spite of control input signal level, but there is no  $F_o$  signal output.
- c5.  $V_{DB}$  level reaches  $UV_{DBr}$ .
- c6. Normal operation: IGBT ON and outputs current by next ON signal (L→H).

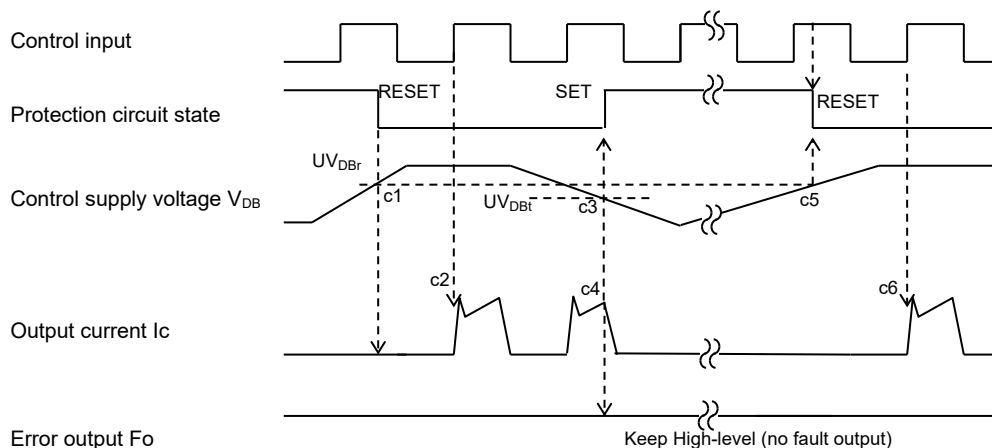

# PSS50NE1CT

TRANSFER MOLDING TYPE  
INSULATED TYPE

## Peripheral circuits

### 1) Pattern Wiring Around N terminal

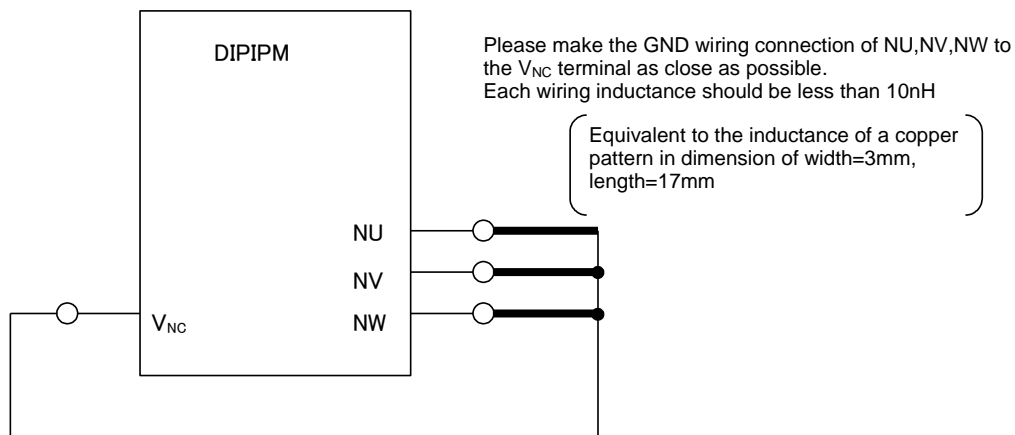

### 2) Circuit Around Control supply voltage $V_{DB}$

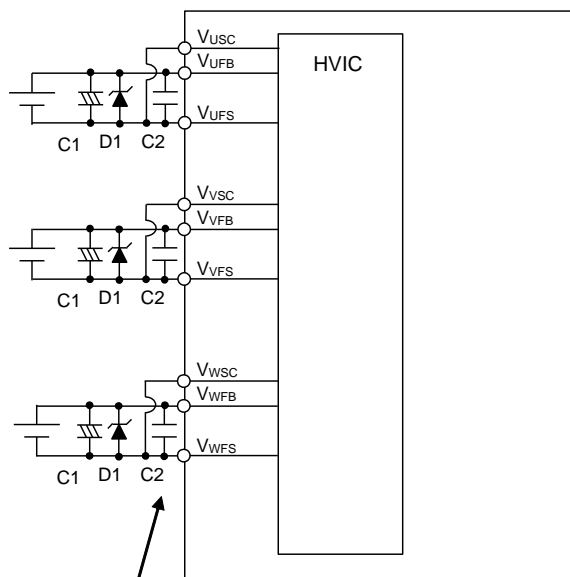

Capacitors C2 should be mounted as close to the terminals of the DIIPM as possible.

- (1) All capacitors, especially C2 should be mounted as close to the terminals of the DIIPM as possible. C1: good temperature, frequency characteristic electrolytic type, and C2:  $0.1\mu\sim 2\mu\text{F}$ , good temperature, frequency and DC bias characteristic type should be used (SMD type is recommended).
- (2) It is recommended to insert a Zener diode (24V,1W) between each pair of control supply terminals to prevent surge destruction.

< DIIPM >  
**PSS50NE1CT**  
 TRANSFER MOLDING TYPE  
 INSULATED TYPE

Fig. 5 Example of Application Circuit

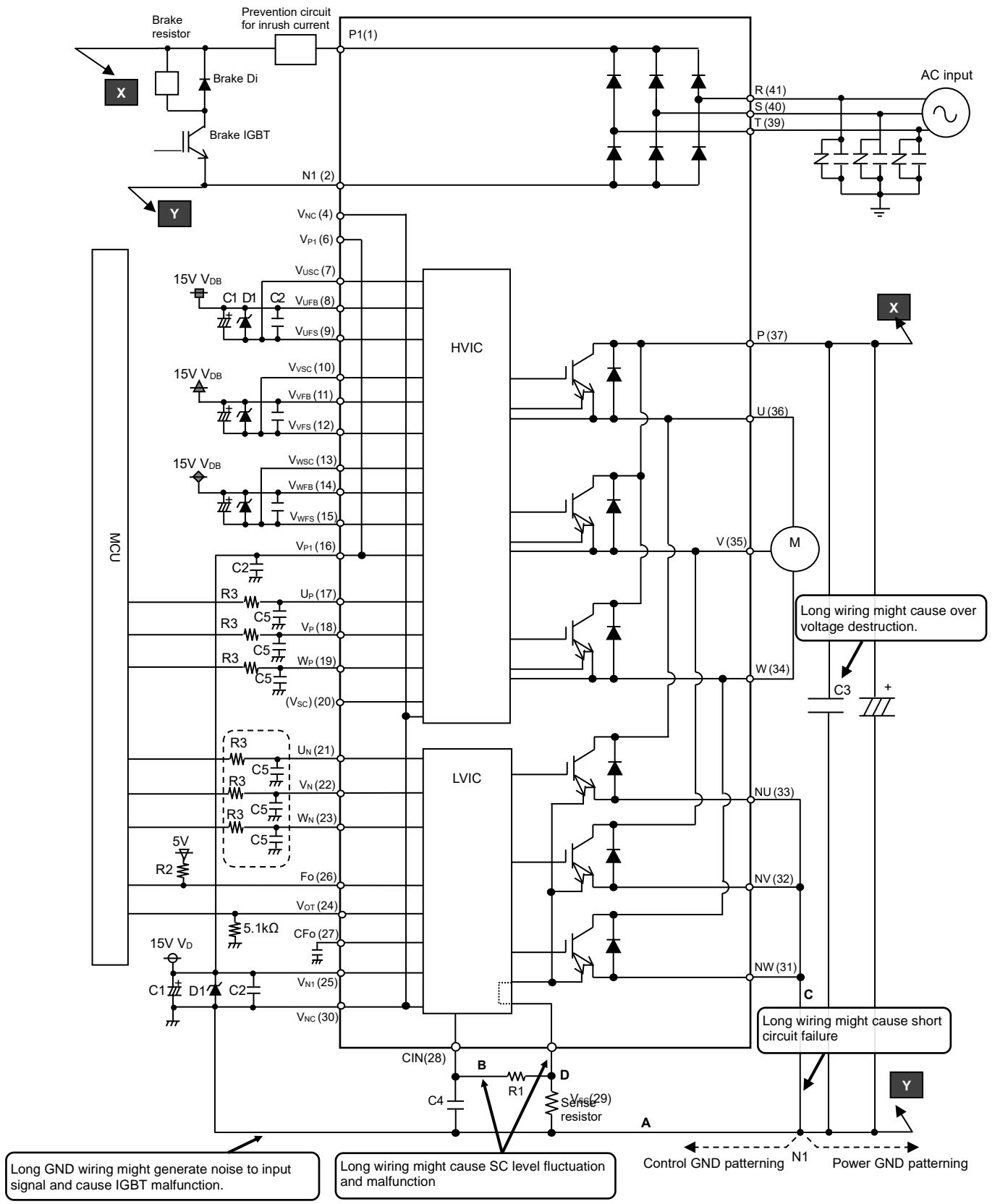

Note for the previous application circuit

- 1 :If control GND and power GND are patterned by common wiring, it may cause malfunction by fluctuation of power GND level. It is recommended to connect control GND and power GND at only a N1 point at which NU, NV, NW are connected to power GND line.
- 2 :It is recommended to insert a Zener diode D1 (24V/1W) between each pair of control supply terminals to prevent surge destruction.
- 3 :To prevent surge destruction, the wiring between the smoothing capacitor and the P, N1 terminals should be as short as possible. Also, insert a snubber capacitor C3 of appropriate capacity (1 $\mu$ F or more) between the P-N1 terminals. Please design the capacity of the snubber capacitor so that it is optimized according to the wiring pattern etc..
- 4 :R1, C4 of RC filter for preventing protection circuit malfunction is recommended to select tight tolerance, temp-compensated type. The time constant R1C4 should be set so that SC current is shut down within 2 $\mu$ s. (1.5 $\mu$ s~2 $\mu$ s is general value.) SC interrupting time might vary with the wiring pattern, so the enough evaluation on the real system is recommended. If R1 is too small, it may lead to delay of protection. So R1 should be min. 10 times larger resistance than Rs. (100 times is recommended.)
- 5 :To prevent erroneous operation, the wiring of A, B, C should be as short as possible.
- 6 :For sense resistor, the variation within 1% (including temperature characteristics), low inductance type is recommended. And the over 0.03W is recommended, but it is necessary to evaluate in your real system finally.
- 7 :To prevent erroneous SC protection, the wiring from V<sub>SC</sub> terminal to CIN filter should be divided at the point D that is close to the terminal of sense resistor. And the wiring should be patterned as short as possible.
- 8 :All capacitors should be mounted as close to the terminals of the DIIPIM as possible. (C1: good temperature, frequency characteristic electrolytic type, and C2: 0.1 $\mu$ ~2.0 $\mu$ F, good temperature, frequency and DC bias characteristic ceramic type are recommended.)
- 9 :Input drive is High-active type. There is a min. 3.3k $\Omega$  pull-down resistor in the input circuit of IC. To prevent malfunction, the wiring of each input should be as short as possible. And it is recommended to insert RC filter (e.g. R3=100 $\Omega$  and C5=1000pF) and confirm the input signal level to meet the turn-on and turn-off threshold voltage. Thanks to HVIC inside the module, direct coupling to MCU without any opto-coupler or transformer isolation is possible.
- 10 :Fo output is open drain type. Fo output will be max 0.95V(@I<sub>Fo</sub>=1mA,25 $^{\circ}$ C), so it should be pulled up to MCU or control power supply (e.g. 5V,15V) by a resistor that makes I<sub>Fo</sub> up to 1mA. (In the case of pulled up to 5V, 10k $\Omega$  is recommended.)
- 11 :Error signal output width (t<sub>Fo</sub>) can be set by the capacitor connected to C<sub>Fo</sub> terminal. C<sub>Fo</sub> (typ.) = t<sub>Fo</sub> x 9.1 x 10<sup>-6</sup> (F)
- 12 :If high frequency noise superimposed to the control supply line, IC malfunction might happen and cause erroneous operation. To avoid such problem, voltage ripple of control supply line should meet dV/dt  $\leq$  +/-1V/ $\mu$ s, V<sub>ripple</sub>  $\leq$  2Vp-p.
- 13 :For DIIPIM, it isn't recommended to drive same load by parallel connection with other phase IGBT or other DIIPIM.
- 14 :No.4 and No.30 V<sub>NC</sub> terminals (GND terminal for control supply) are connected mutually inside of DIIPIM+ and also No.6 and No.16 V<sub>P1</sub> terminals are connected mutually inside, please connect either No.4 or No.30 terminal to GND and also connect either No.6 or No.16 terminal to supply and make the unused terminal leave no connection.
- 15 :Please connect the V<sub>USC</sub>-V<sub>UFS</sub>(7-9 terminal), V<sub>VSC</sub>-V<sub>VFS</sub>(10-12 terminal), V<sub>WSC</sub>-V<sub>WFS</sub>(13-15terminal) externally.
- 16 :Although 3, 5, 20 and 38 terminals are dummy terminals, it may have an electric potential, so make it a no connection.

Fig. 6 MCU I/O Interface Circuit

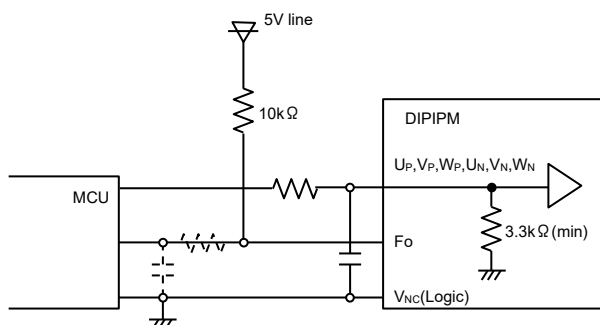

Note)

Design for input RC filter depends on the PWM control scheme used in the application and the wiring impedance of the printed circuit board.

The DIIPIM input signal interface integrates a min. 3.3k $\Omega$  pull-down resistor. Therefore, when using RC filter, be careful to satisfy turn-on threshold voltage requirement.

Fo output is open drain type. It should be pulled up to the positive side of 5V or 15V power supply with the resistor that limits Fo sink current I<sub>Fo</sub> under 1mA. In the case of pulling up to 5V supply, over 5.1k $\Omega$  is needed. (10k $\Omega$  is recommended.)

# PSS50NE1CT

TRANSFER MOLDING TYPE  
INSULATED TYPE

Fig. 7 PCB through-hole pattern

The recommended through-hole positions and diameters layout are shown.

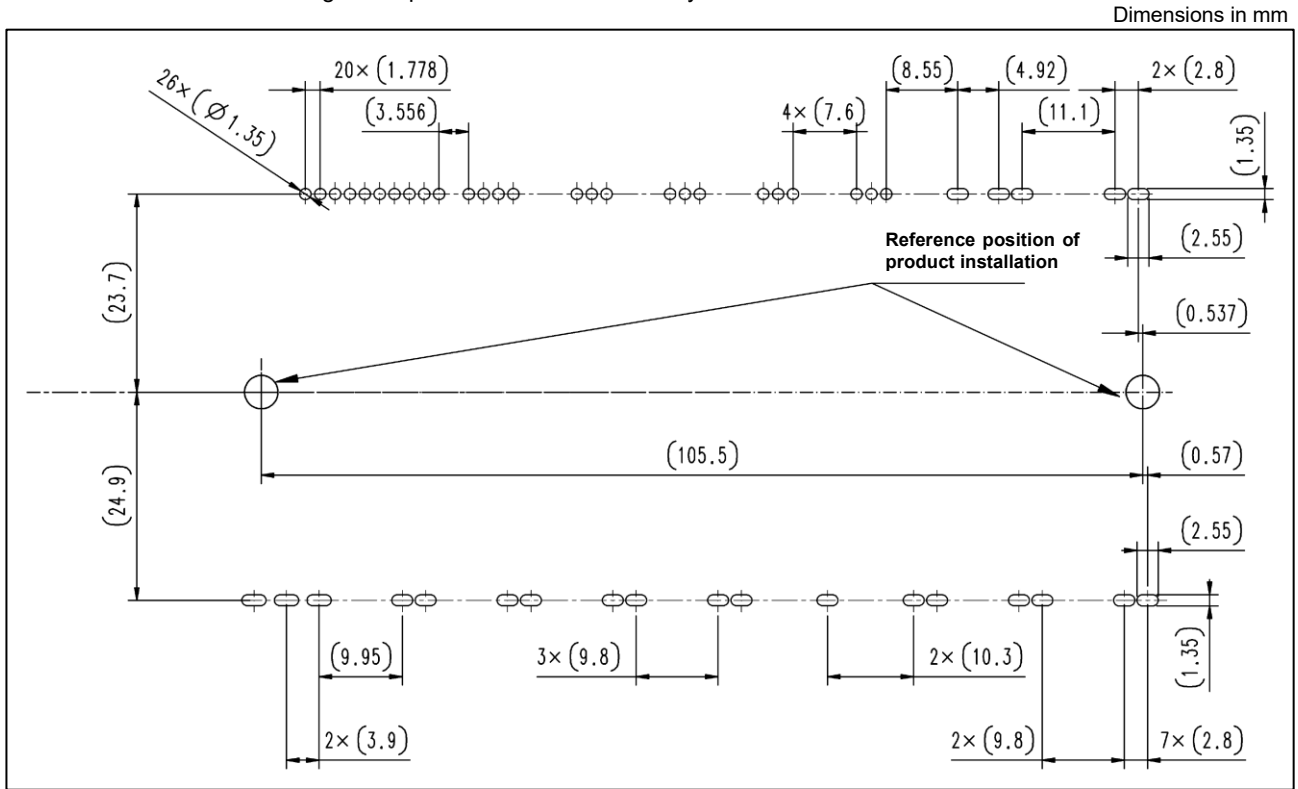

< DIIPM >

# PSS50NE1CT

TRANSFER MOLDING TYPE  
INSULATED TYPE

Fig. 8 Package Outlines

Dimensions in mm

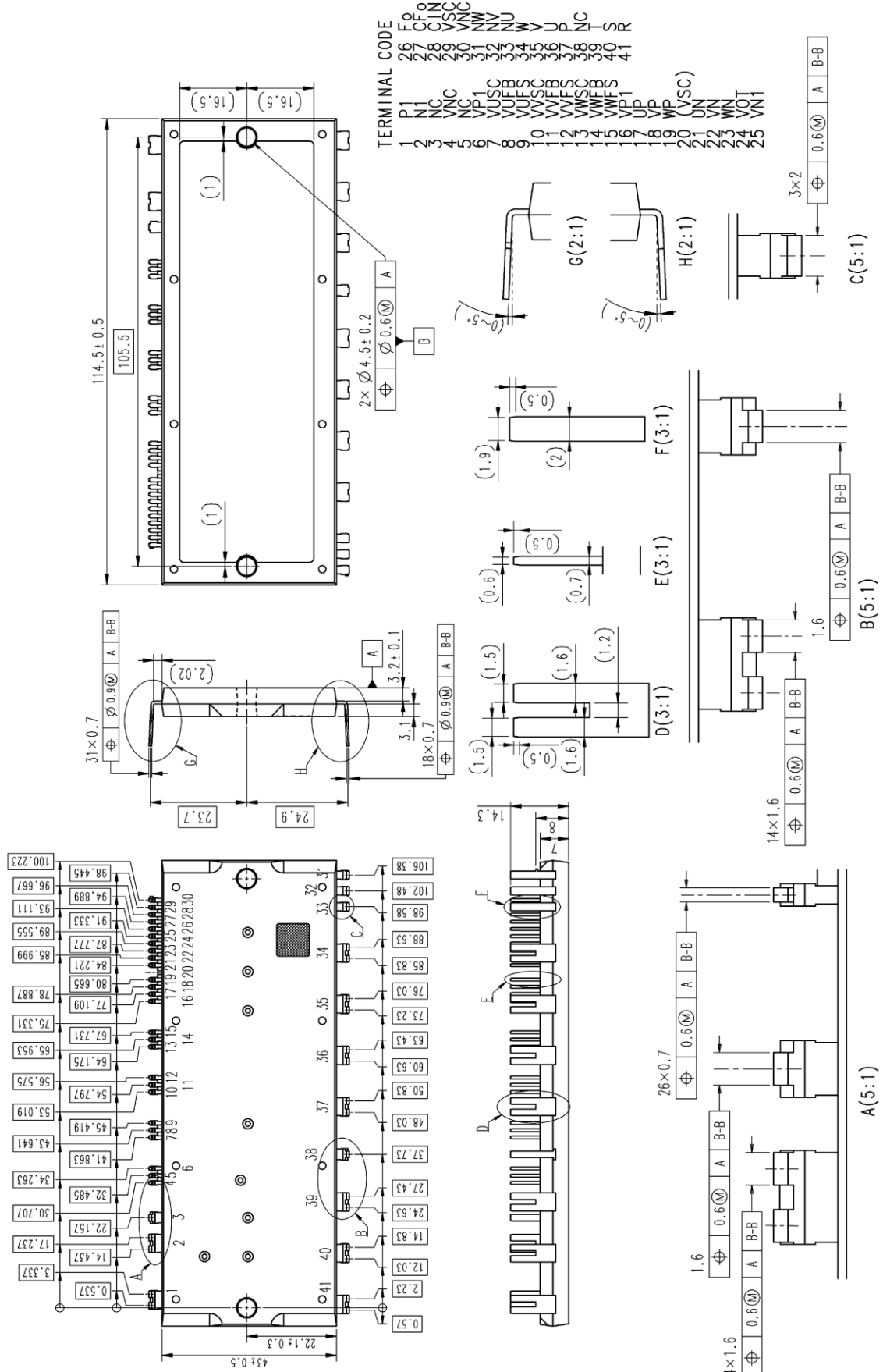

### **Important Notice**

The information contained in this datasheet shall in no event be regarded as a guarantee of conditions or characteristics. This product has to be used within its specified maximum ratings, and is subject to customer's compliance with any applicable legal requirement, norms and standards.

Except as otherwise explicitly approved by Mitsubishi Electric Corporation in a written document signed by authorized representatives of Mitsubishi Electric Corporation, our products may not be used in any applications where a failure of the product or any consequences of the use thereof can reasonably be expected to result in personal injury.

In usage of power semiconductor, there is always the possibility that trouble may occur with them by the reliability lifetime such as Power Cycle, Thermal Cycle or others, or when used under special circumstances (e.g. condensation, high humidity, dusty, salty, highlands, environment with lots of organic matter / corrosive gas / explosive gas, or situations which terminals of semiconductor products receive strong mechanical stress). Therefore, please pay sufficient attention to such circumstances. Further, depending on the technical requirements, our semiconductor products may contain environmental regulation substances, etc. If there is necessity of detailed confirmation, please contact our nearest sales branch or distributor.

The contents or data contained in this datasheet are exclusively intended for technically trained staff. Customer's technical departments should take responsibility to evaluate the suitability of Mitsubishi Electric Corporation product for the intended application and the completeness of the product data with respect to such application. In the customer's research and development, please evaluate it not only with a single semiconductor product but also in the entire system, and judge whether it's applicable. As required, pay close attention to the safety design by installing appropriate fuse or circuit breaker between a power supply and semiconductor products to prevent secondary damage. Please also pay attention to the application note and the related technical information.

### **Keep safety first in your circuit designs!**

Mitsubishi Electric Corporation puts the maximum effort into making semiconductor products better and more reliable, but there is always the possibility that trouble may occur with them. Trouble with semiconductors may lead to personal injury, fire or property damage. Remember to give due consideration to safety when making your circuit designs, with appropriate measures such as (i) placement of substitutive, auxiliary circuits, (ii) use of non-flammable material or (iii) prevention against any malfunction or mishap.

### **Notes regarding these materials**

- These materials are intended as a reference to assist our customers in the selection of the Mitsubishi Electric Semiconductor product best suited to the customer's application; they do not convey any license under any intellectual property rights, or any other rights, belonging to Mitsubishi Electric Corporation or a third party.
- Mitsubishi Electric Corporation assumes no responsibility for any damage, or infringement of any third-party's rights, originating in the use of any product data, diagrams, charts, programs, algorithms, or circuit application examples contained in these materials.
- All information contained in these materials, including product data, diagrams, charts, programs and algorithms represents information on products at the time of publication of these materials, and are subject to change by Mitsubishi Electric Corporation without notice due to product improvements or other reasons. It is therefore recommended that customers contact Mitsubishi Electric Corporation or an authorized Mitsubishi Electric Semiconductor product distributor for the latest product information before purchasing a product listed herein.  
The information described here may contain technical inaccuracies or typographical errors. Mitsubishi Electric Corporation assumes no responsibility for any damage, liability, or other loss rising from these inaccuracies or errors.  
Please also pay attention to information published by Mitsubishi Electric Corporation by various means, including the Mitsubishi Electric Semiconductor home page (<http://www.MitsubishiElectric.com/semiconductors/>).
- When using any or all of the information contained in these materials, including product data, diagrams, charts, programs, and algorithms, please be sure to evaluate all information as a total system before making a final decision on the applicability of the information and products. Mitsubishi Electric Corporation assumes no responsibility for any damage, liability or other loss resulting from the information contained herein.
- Mitsubishi Electric Corporation semiconductors are not designed or manufactured for use in a device or system that is used under circumstances in which human life is potentially at stake. Please contact Mitsubishi Electric Corporation or an authorized Mitsubishi Electric Semiconductor product distributor when considering the use of a product contained herein for any specific purposes, such as apparatus or systems for transportation, vehicular, medical, aerospace, nuclear, or undersea repeater use.
- The prior written approval of Mitsubishi Electric Corporation is necessary to reprint or reproduce in whole or in part these materials.
- If these products or technologies are subject to the Japanese export control restrictions, they must be exported under a license from the Japanese government and cannot be imported into a country other than the approved destination.  
Any diversion or re-export contrary to the export control laws and regulations of Japan and/or the country of destination is prohibited.
- Please contact Mitsubishi Electric Corporation or an authorized Mitsubishi Electric Semiconductor product distributor for further details on these materials or the products contained therein.